

Series CBQ2

ø20, ø25, ø32, ø40
ø50, ø63, ø80, ø100

Replacement
Procedure is
P.290

Construction

ø32 to ø63

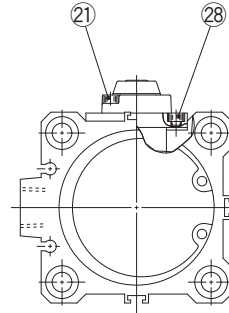
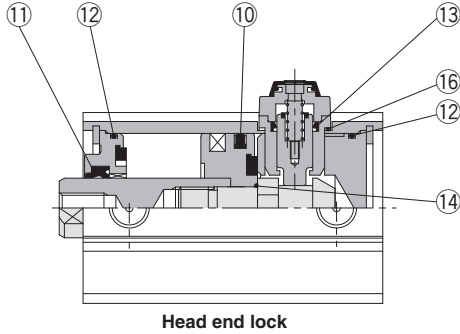

* The numbers are the same as the "Construction" of the CQ2 series catalog (CAT.ES20-205).

Seal Kit List

No.	Description	Material	Note
⑩	Piston seal	NBR	
⑪	Rod seal	NBR	
⑫	Tube gasket	NBR	Using 4 pcs. for ø80, ø100
⑬	Lock piston seal	NBR	
⑭	Piston gasket	NBR	Nothing for ø20, ø25
⑯	Gasket	NBR	
⑰	Hexagon socket head cap screw	Alloy steel	Black zinc chromated
⑱	Hexagon socket head cap screw	Alloy steel	Nickel plated

14 is a non-replaceable part, so it is not included in the seal kit.

Replacement Parts: Seal Kit

Bore size (mm)	Kit no.	Contents
20	CBQ2B20-PS	Set of left nos. ⑩, ⑪, ⑫, ⑬, ⑯, ⑰, ⑱ and a grease pack.
25	CBQ2B25-PS	
32	CBQ2B32-PS	
40	CBQ2B40-PS	
50	CBQ2B50-PS	
63	CBQ2B63-PS	
80	CBQ2B80-PS	
100	CBQ2B100-PS	

* Seal kit includes ⑩, ⑪, ⑫, ⑬, ⑯, ⑰, ⑱. Order the seal kit, based on each bore size.

* Since the seal kit does not include a grease pack, order it separately.
Grease pack part no.: GR-S-010 (10 g)

Actuators

Modular F.R.L.
Pressure Control Equipment

Air Preparation
Equipment

Industrial Filters

Replacement
Procedure

Actuators

Modular F.R.L.
Pressure Control Equipment

Industrial Filters