

Series MY1M

ø16, ø20, ø25, ø32
ø40, ø50, ø63

Replacement
Procedure is
P.306

Construction

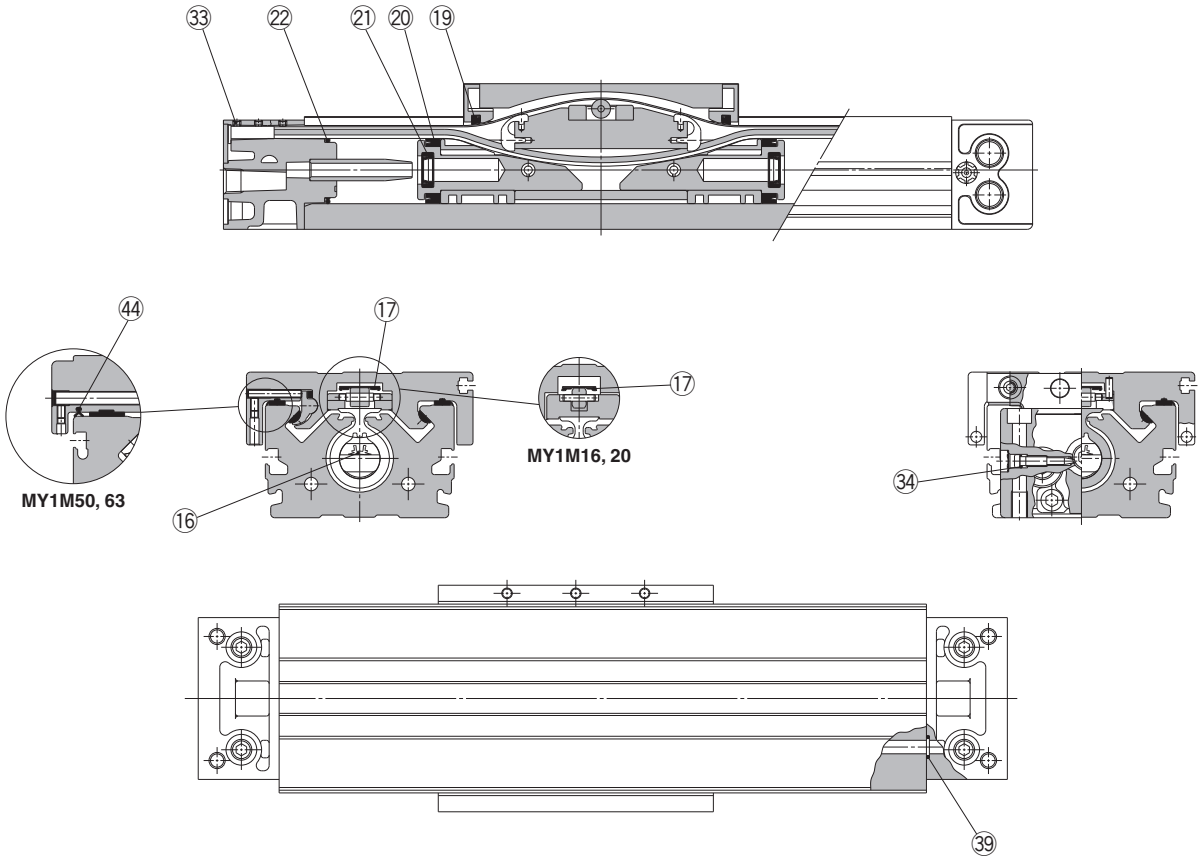

* The numbers are the same as the "Construction" of the Best Pneumatics No.2 Series MY1M.

Seal Kit List (16, 17, 34 and 44 are not included in the seal kit. Order them as required with by individual part numbers.)

No.	Description	Qty.	MY1M16	MY1M20	MY1M25	MY1M32	MY1M40	MY1M50	MY1M63
16	Seal belt	1	MY16-16A-Stroke	MY20-16A-Stroke	MY25-16A-Stroke	MY32-16A-Stroke	MY40-16A-Stroke	MY50-16A-Stroke	MY63-16A-Stroke
17	Dust seal band	1	MY16-16B-Stroke	MY20-16B-Stroke	MY25-16B-Stroke	MY32-16B-Stroke	MY40-16B-Stroke	MY50-16B-Stroke	MY63-16B-Stroke
34	O-ring	2	KA00309 (ø4 x ø1.8 x ø1.1)	KA00311 (ø5.1 x ø3 x ø1.05)	KA00311 (ø5.1 x ø3 x ø1.05)	KA00320 (ø7.15 x ø3.75 x ø1.7)	KA00402 (ø8.3 x ø4.5 x ø1.9)	KA00777	KA00777
44	Side scraper	2	—	—	—	—	—	MYM50-15CK0502B	MYM63-15CK0503B
19	Scraper	2							
20	Piston seal	2							
21	Cushion seal	2	MY1M16-PS	MY1M20-PS	MY1M25-PS	MY1M32-PS	MY1M40-PS	MY1M50-PS	MY1M63-PS
22	Tube gasket	2							
39	O-ring	4							

* Seal kit includes 19, 20, 21, 22 and 39. Order the seal kit based on each bore size.

* Seal kit includes a grease pack (10 g).

When 16 and 17 are shipped independently, a grease pack is included. (10 g per 1000 strokes)

Order with the following part number when only the grease pack is needed.

Grease pack part no.: GR-S-010 (10 g), GR-S-020 (20 g)

Note) Two kinds of dust seal bands are available. Verify the type to use, since the part number varies depending on the treatment of the hexagon socket head set screw 33.

A: Black zinc chromated → MY□□-16B-stroke, B: Nickel plated → MY□□-16BW-stroke