

# Series CNA2

ø40, ø50, ø63  
ø80, ø100

Replacement  
Procedure is  
p.351

## Construction

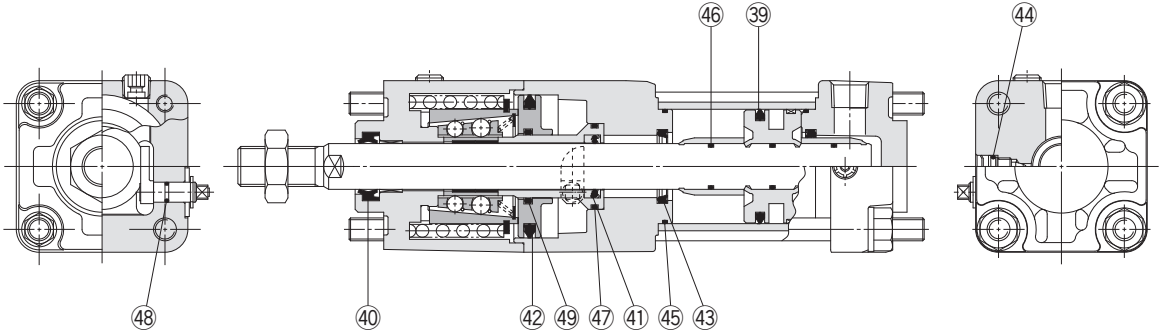

\* The numbers are the same as the "Construction" of the CNA2 series catalog (CAT.ES20-206).

### Seal Kit List

No.	Description	Material	Note
39	Piston seal	NBR	41, 42, 44 and 46 to 49 are non-replaceable parts, so they are not included in the seal kit.
40	Rod seal A	NBR	
41	Rod seal B	NBR	
42	Release piston seal	NBR	
43	Cushion seal	Urethane	
44	Cushion valve seal	NBR	
45	Tube gasket	NBR	
46	Piston gasket	NBR	
47	Piston guide gasket	NBR	
48	Unlocking cam gasket	NBR	
49	O-ring	NBR	

### Replacement Parts: Seal Kit

Bore size (mm)	Kit no.	Contents
40	MB40-PS	Set of left nos. 39, 40, 43, 45
50	MB50-PS	
63	MB63-PS	
80	MB80-PS	
100	MB100-PS	

\* Since the lock of the CNA2 series cannot be disassembled and is normally replaced as a unit, kits are for the cylinder section only. These can be ordered using the order number for each bore size.

\* Seal kit includes a grease pack (ø40 and ø50: 10 g, ø63 and ø80: 20 g, ø100: 30 g).

Order with the following part number when only the grease pack is needed.

**Grease pack part no.:** GR-S-010 (10 g), GR-S-020 (20 g)

\* As for the center trunnion type, it is very difficult to adjust the position of the trunnion bracket and the center of the axis. Therefore repair at SMC is recommended.

### Replacement Parts: Lock Unit

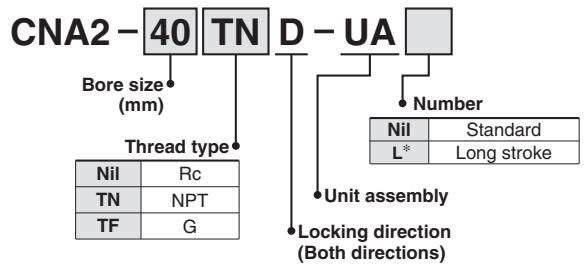

\* The lock unit for a long-stroke cylinder is only applicable for flange type with bore size ø50 to ø100 and stroke 1001 or more. (Example: CNA2-100D-UAL)