

Series MGG

ø20, ø25, ø32, ø40, ø50

Construction

ø20 to ø50/MGG□□

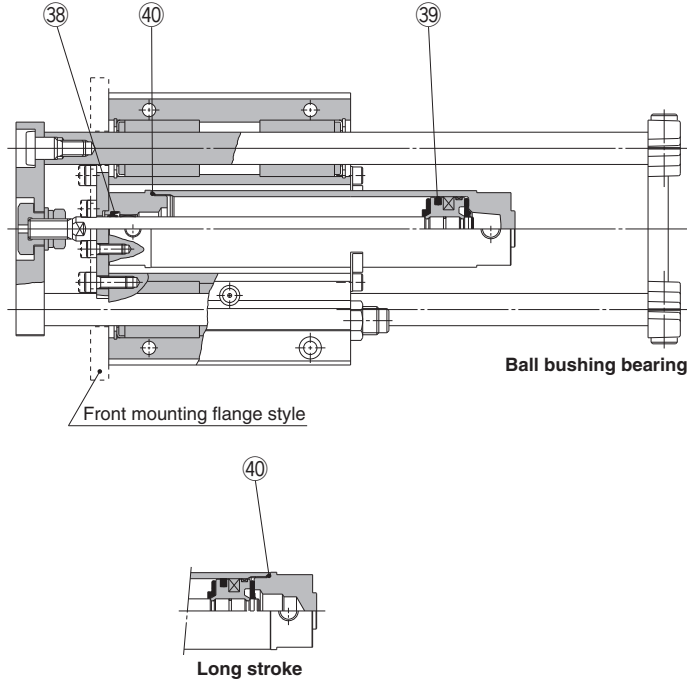

* The numbers are the same as the "Construction" of the Best Pneumatics No.3 Series MGG.

Seal Kit List

No.	Description	Material	Note
38	Rod seal	NBR	
39	Piston seal		
40	Tube gasket		

Replacement Parts: Seal Kit

Bore size (mm)	Kit no.	Contents
20	CG1N20-PS	Set of left nos. 38, 39, 40
25	CG1N25-PS	
32	CG1N32-PS	
40	CG1N40-PS	

* Seal kit includes 38 to 40. Order the seal kit, based on each bore size.

* Seal kit includes a grease pack (10 g).

Order with the following part number when only the grease pack is needed.

Grease pack part no.: GR-S-010 (10 g)

⚠ Caution

When disassembling cylinders with bore sizes of ø20 through ø40, grip the double flat part of either the tube cover or the rod cover with a vise and loosen the other side with a wrench or an adjustable angle wrench, and then remove the cover. When re-tightening, tighten approximately 2 degrees more than the original position.

(Cylinders with ø50 or larger bore sizes are tightened with a large tightening torque and cannot be disassembled. Please contact SMC when disassemble is required.)

Series MGG

ø63, ø80, ø100

Construction

ø63 to ø100/MGG□B

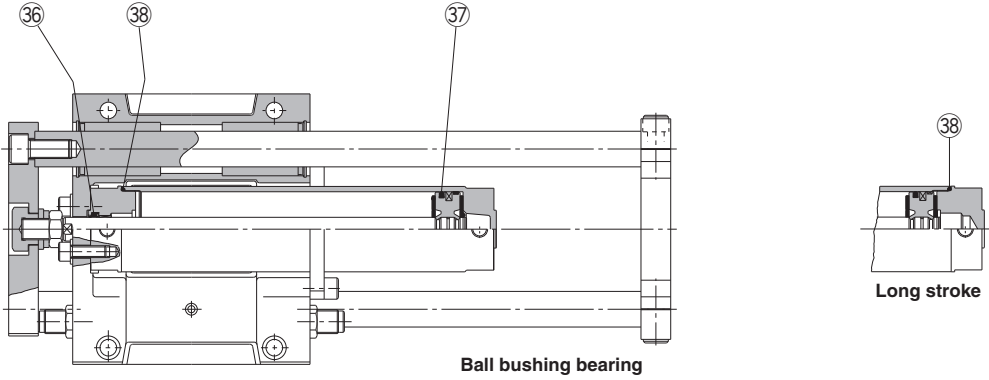

ø63 to ø100/MGG□F

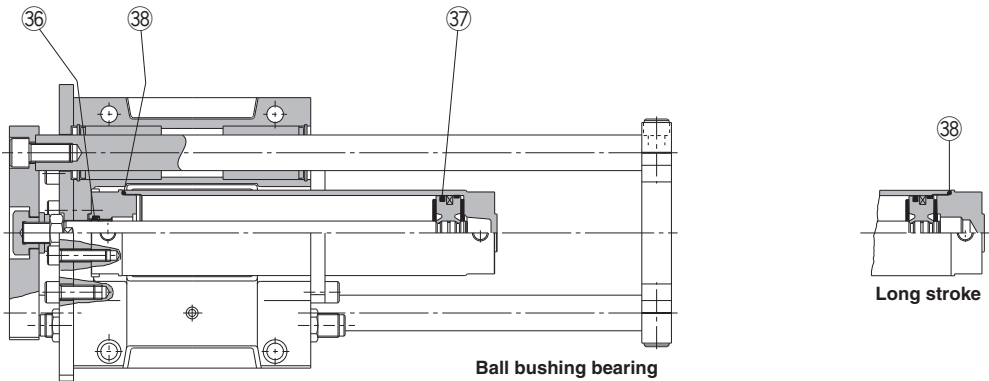

* The numbers are the same as the "Construction" of the Best Pneumatics No.3 Series MGG.

Seal Kit List

No.	Description	Material	Note
36	Rod seal	NBR	
37	Piston seal		
38	Tube gasket		

⚠ Caution

Basic cylinders with a bore size of ø50 cannot be disassembled. (Cylinders with ø50 or larger bore sizes are tightened with a large tightening torque and cannot be disassembled. Please contact SMC when disassemble is required.)

Actuators

Modular F.R.L.
Pressure Control Equipment

Air Preparation
Equipment

Industrial Filters

Replacement
Procedure

Actuators

Modular F.R.L.
Pressure Control Equipment

Industrial Filters

Series MGG

ø20, ø25, ø32, ø40
ø50, ø63, ø80, ø100

Construction

ø20 to ø100/MGG□□

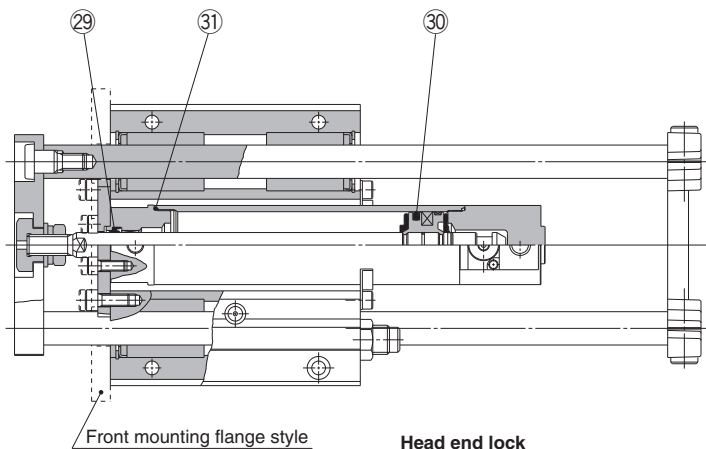

Manual release (Lock type)

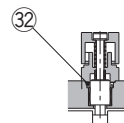

ø20 to ø63

* The numbers are the same as the "Construction" of the Best Pneumatics No.3 Series MGG.

Seal Kit List

No.	Description	Material	Note
29	Rod seal	NBR	
30	Piston seal		
31	Tube gasket		
32	Lock piston seal		

Replacement Parts: Seal Kit

Bore size (mm)	Kit no.	Contents
20	CBG1N20-PS	Set of left nos. 29, 30, 31, 32
25	CBG1N25-PS	
32	CBG1N32-PS	
40	CBG1N40-PS	

* Seal kit includes 29 to 32. Order the seal kit, based on each bore size.

* Seal kit includes a grease pack (10 g).

Order with the following part number when only the grease pack is needed.

Grease pack part no.: GR-S-010 (10 g)

⚠ Caution

Basic cylinders with a bore size of ø50 cannot be disassembled.

(Cylinders with ø50 or larger bore sizes are tightened with a large tightening torque and cannot be disassembled. Please contact SMC when disassemble is required.)