



Superior Clamping and Gripping



## Product Information

Co-act Gripper EGH

## Easy. Flexible. Plug & work.

### Co-act gripper EGH

Flexible gripper with long, adjustable stroke for simple automation with cobots

#### Field of application

Flexible gripping and moving of small to medium-sized workpieces in the areas of handling, assembly, and electronics.

#### Advantages – Your benefits

**Long and freely programmable stroke** for flexible workpiece handling

**Plug & Work** for a quick and simple start of production

**Integrated status display** For a visual indicator of the application state

**Control via IO-Link** enables the repositioning of the gripper finger and the evaluation of the gripper condition

**Gripping movement with parallel kinematics** for constant gripping force over the entire stroke

**Easily accessible assembly quick-release fastener** for quick and easy attachment of the gripper to the robot

**Optionally attachable flexible fingers** for increased flexibility and the gripper's range of application



 <p>Sizes Quantity: 1</p>	 <p>Weight 0.95 kg</p>	 <p>Gripping force 100 N</p>	 <p>Stroke per jaw 40 mm</p>	 <p>Workpiece weight 0.5 kg</p>
--	---	---	---	--

## Functional description

The multi-stage gear transmission is driven by a brushless servomotor. The base jaws of the gripper are driven by three parallel output pinions, which have integrated gear racks for this purpose. The jaws are therefore driven by

the rack-and-pinion principle, which converts the rotary movement of the servomotor and the gear into the linear movement of the base jaws.

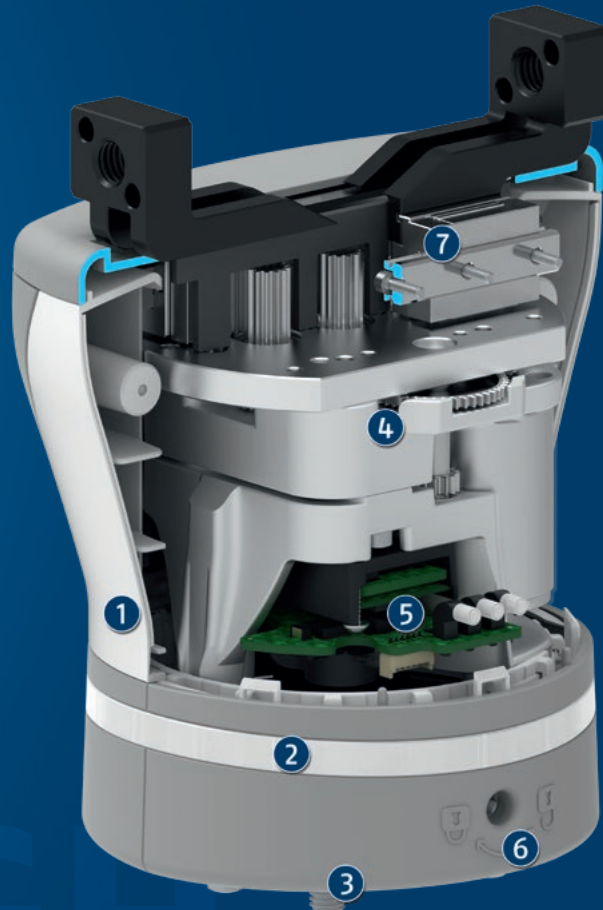

① **Gripper housing**  
made from high-quality plastic

② **LED strip light**  
for an application-specific status display

③ **ISO flange**  
for direct adaptation to the robot

④ **Drive unit**  
consisting of gear and servomotor

⑤ **Integrated electronics**  
With IO-Link interface and LED status display

⑥ **Locking mechanism**  
for simple and quick assembly on the robot

⑦ **Base jaw with linear guide**  
for adaptation of gripper fingers

## Detailed functional description

### Long, freely programmable stroke with parallel finger movement



The long stroke of the SCHUNK Co-act gripper EGH can cover a very wide range of workpieces. The gripper fingers are particularly suited for positioning over the entire stroke. The robust parallel movement of the fingers ensures constant gripping force at a position over the entire stroke. Height compensation for the robot is not required.

### Easy and quick assembly

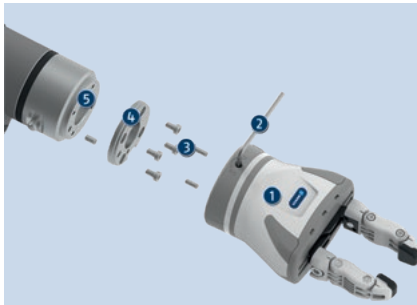

The design of the SCHUNK Co-act gripper EGH enables the gripper to be attached to the robot quickly and easily. First the included adapter plate is attached to the robot flange using the supplied fastening material. Subsequently, due to the assembly quick-release fastener, the gripper can be attached easily to the adapter plate with the enclosed hexagon socket wrench. Finally, you just need to establish the electric connection.

- ① Co-act gripper EGH
- ② Hexagon socket wrench
- ③ Mounting material
- ④ Adapter plate
- ⑤ Robot flange

### Starter kit for simple Plug & Work

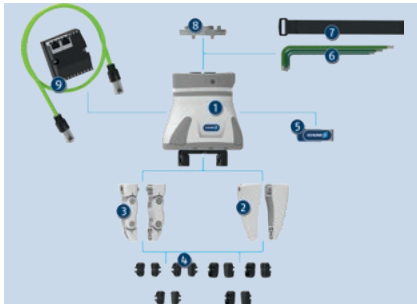

A starter kit is available for quick and easy installation of the SCHUNK Co-act gripper EGH. This contains all the necessary components to successfully mount the gripper onto the robot and to put it into operation. The starter kit comprises the following materials:

- ① Co-act gripper EGH
- ② Rigid attachment finger
- ③ Flexible attachment finger
- ④ Finger inserts
- ⑤ USB stick with URcap plug-in
- ⑥ Tool
- ⑦ Velcro tapes for fastening the cable to the robot
- ⑧ Adapter plate
- ⑨ IO-Link master with connection cable

## Status display via LED light band

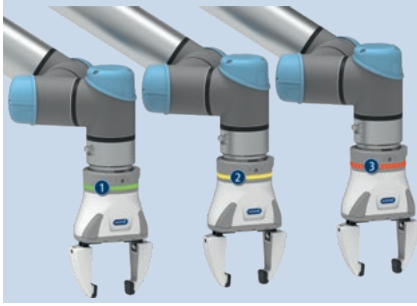

The SCHUNK Co-act gripper EGH has an integrated LED light strip that can indicate the gripper's operating status. The light band can be illuminated in three different colors. They can be defined on an application-specific basis and controlled individually via digital signals.

- ① Illuminated green light band
- ② Illuminated yellow light band
- ③ Illuminated red light band

## Flexible fingers for maximum variability



The SCHUNK Co-act gripper EGH can be equipped with flexible fingers. These are also included in the starter kit. With two adjustable finger joints, the gripping width is easy to adjust according to individual requirements. This expands the gripper's range of application, and exchanging fingers or the entire gripper is no longer necessary.

## General notes about the series

**Operating principle:** Rack and pinion principle

**Base jaw material:** Steel

**Actuation:** servo-electric, via brushless DC servomotor

**Warranty:** 12 months

**Gripping force:** is the arithmetic sum of the individual force applied to each jaw at distance P (see illustration).

**Finger length:** is measured from the reference surface as the distance P in direction to the main axis.

**Repeat accuracy (gripping):** is defined as a distribution of the end Position for 100 consecutive strokes.

**Repeat accuracy (positioning, unidirectional):** defined as the spread of the actual position of the base jaws after 100 consecutive movements to a target position from the same direction under constant conditions.

**Repeat accuracy (positioning, bi-directional):** defined as the spread of the actual position of the base jaws after 100 consecutive movements to a target position from both directions under constant conditions.

**Workpiece weight:** is calculated for force-fit gripping with a coefficient of static friction of 0.1 and a safety factor of 2 against workpiece slippage at acceleration due to gravity  $g$ . For form-fit or capture gripping, there are significantly higher permissible workpiece weights.

**Closing and opening times:** are purely the times that the base jaws or fingers are in motion. PLC reaction times are not included in the above-mentioned times and must be taken into consideration when determining cycle times.

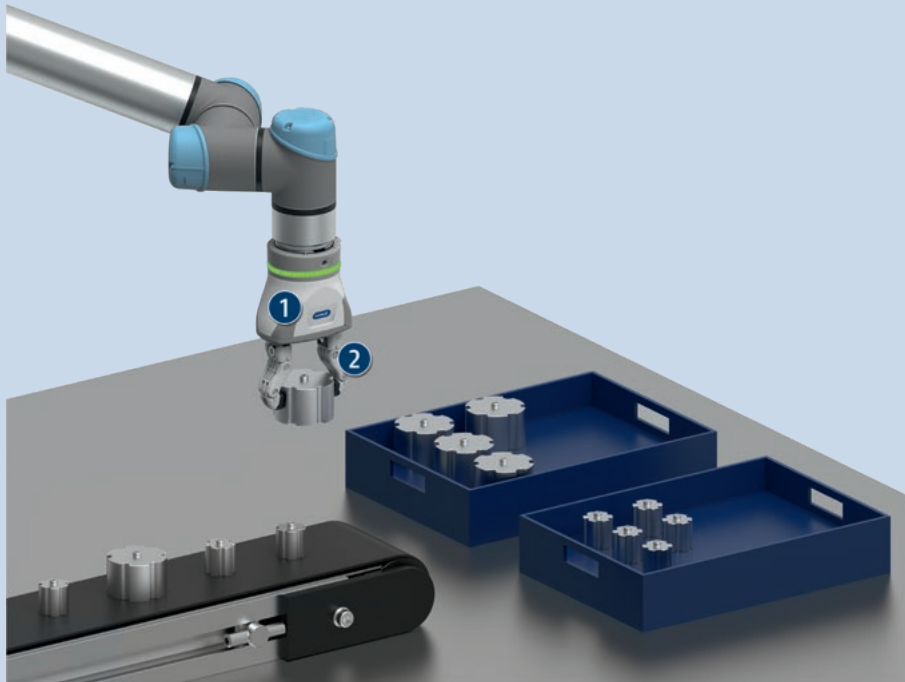

## Application example

Pick & Place application for sorting randomly arriving workpieces into trays. The gripper enables the handling of workpieces with different diameters.

① Co-act gripper EGH

② Flexible fingers

## SCHUNK offers more ...

The following components make the product EGH even more productive – the suitable addition for the highest functionality, flexibility, reliability, and controlled production.



Manual change system



Rigid attachment finger



Flexible attachment finger

① For more information on these products can be found on the following product pages or at [schunk.com](http://schunk.com). Please contact us: SCHUNK technical hotline +49-7133-103-2696

## Options and special information

**Starter kit:** The starter package contains all necessary components to mount the gripper to the robot and to put it into operation. In addition to the gripper, the content includes the necessary fastening materials, tools, attachment fingers, IO-Link master and a USB stick.

**Attachment fingers:** The attachment fingers are provided in both rigid and flexible form. In addition, finger inserts in solid and soft design with three different contours are included. This means that a wide variety of gripping tasks can already be implemented with the starter kit.

**IO-Link master:** The included IO-Link master has protection class IP20 and can be installed in the robot's control cabinet. Connection cables for communication and power supply of the master as well as optional mounting material are included in the scope of delivery.

**URCaps plugin:** For the Co-act gripper EGH, a plug-in for collaborative robots from Universal Robots is provided on the enclosed USB stick. This is compatible with Universal Robots software versions 5.3 to 5.5.

**Documentation:** The starter package already includes assembly instructions for the gripper. Further information including software manual for the plug in for Universal Robots can be found at [www.schunk.com](http://www.schunk.com).

# EGH 80

Co-act Gripper



## Gripping force I.D. gripping

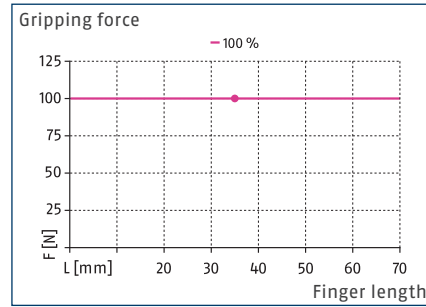

## Dimensions and maximum loads

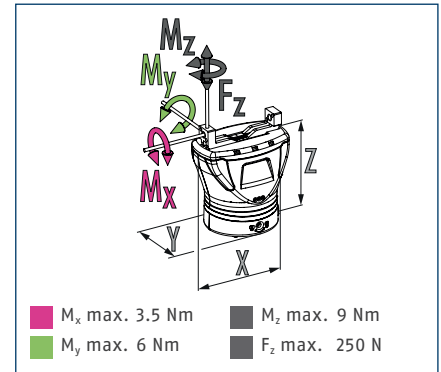

① The indicated torques and forces are static values, apply for each base jaw, and may occur simultaneously.

## Technical data

Characterization	EGH 80-IOL-N-UREK Starter	
ID	1399917	
<b>General operating data</b>		
Compatible robot	UR 3/5/10/16	
LED strip light	integrated	
Displayable colors	green, yellow, red	
Dimensions X x Y x Z	[mm]	114 x 86.5 x 133
<b>Mechanical operating data</b>		
Stroke per jaw	[mm]	40
Min./max. gripping force	[N]	-/100
Min./max. force per jaw	[N]	-/50
Recommended workpiece weight	[kg]	0.5
Max. permissible finger length	[mm]	70
Max. permissible mass per finger	[kg]	0.2
Repeat accuracy (positioning, unidirectional)	[mm]	±0.1
Repeat accuracy (positioning, bi-directional)	[mm]	±0.1
Closing/opening time	[s]	0.8/0.8
Weight	[kg]	0.95
Weight incl. cable	[kg]	1.2
Min./max. ambient temperature	[°C]	5/55
Protection class IP	20	
Cable connector/cable end	open wire strands	
Cable length	[m]	4
<b>Electrical operating data</b>		
Nominal voltage	[V]	24
Nominal current	[A]	0.2
Max. current	[A]	2
Communication interface/ specification	IO-Link/V1.1	
Transmission rate	COM2	
Port	Class B	
Number of digital inputs (light band)	2	



## Main view

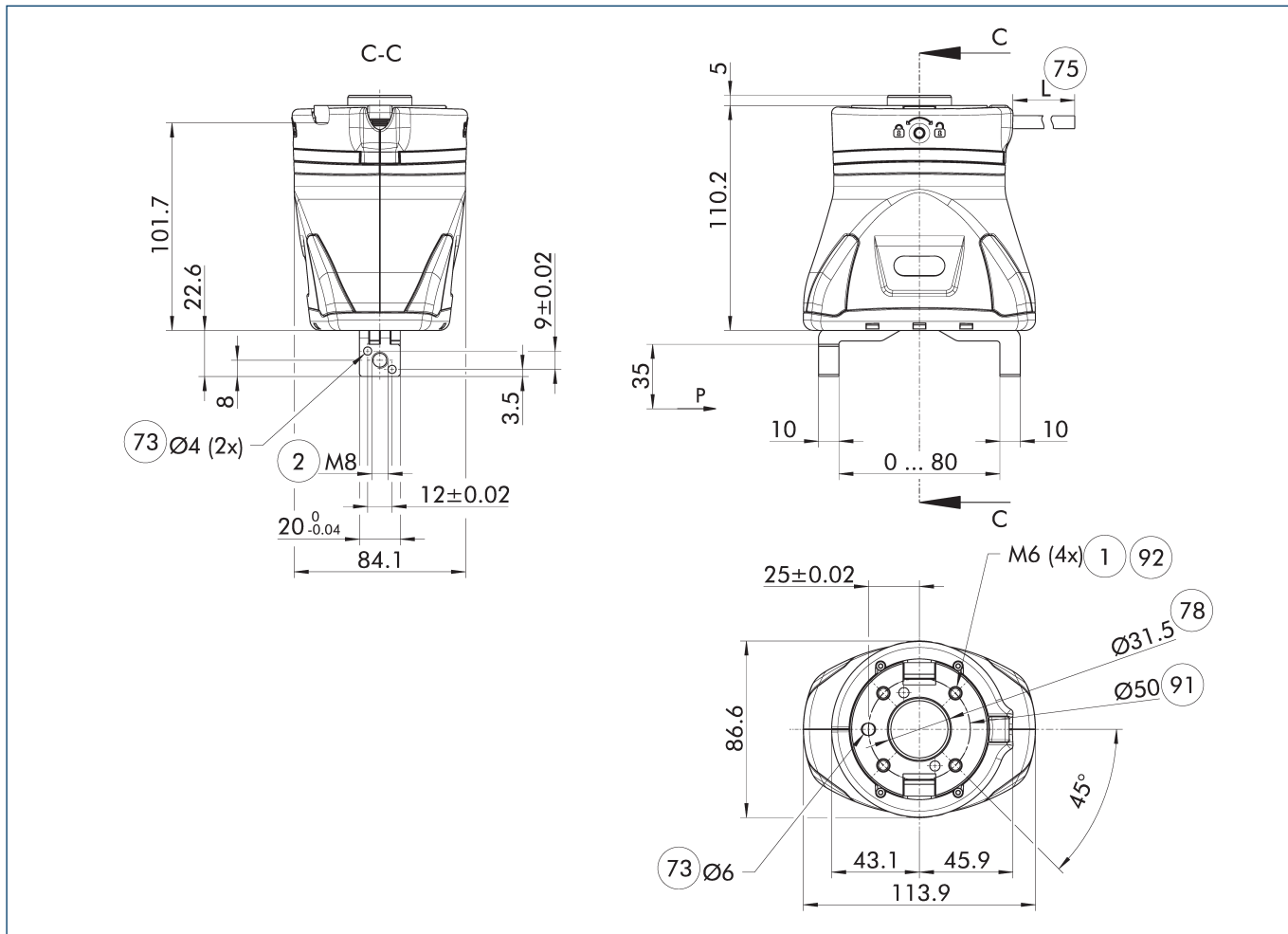

The drawing shows the basic version of the gripper with open jaws, without dimensional consideration of the options described below.

- ① Gripper connection
- ② Finger connection
- ⑦③ Fit for centering pins
- ⑦⑤ Cable length
- ⑦⑧ Fit for centering
- ⑨① DIN ISO-9409 bolt circle
- ⑨② Through holes for screw connections

## Maximum permitted finger projection

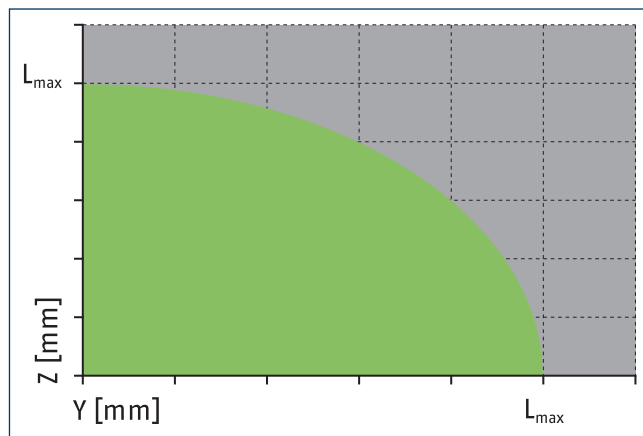
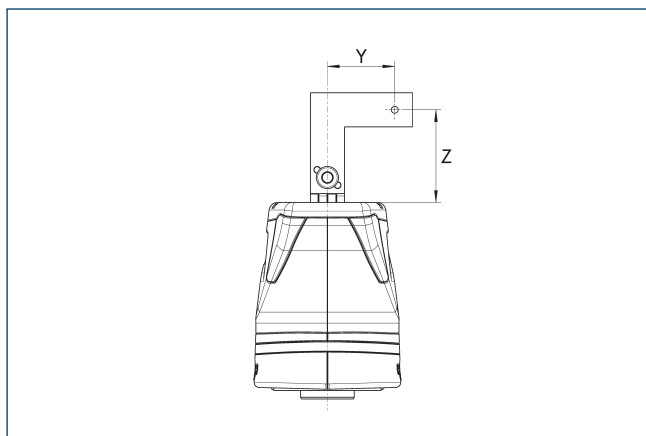

$L_{max}$  is equivalent to the maximum permitted finger length, see the technical data table.

# EGH 80

Co-act Gripper

## Flexible top jaw AUB-F EGH

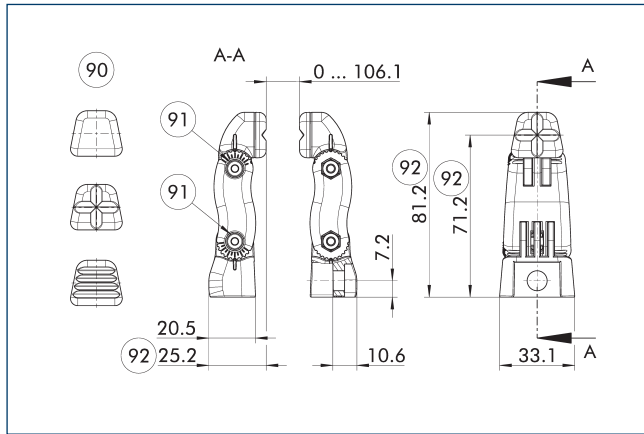

- 90 Finger inserts
- 91 Screw for adjustment
- 92 variable dimensions

The flexible top jaws are specifically designed for the EGH gripper. The top jaws are mutually adjustable via two clampings in the clamping range. Depending on the application and workpiece, one of the supplied finger inserts can be used. The finger inserts are manufactured from rigid or elastic material. The top jaws are used for initial commissioning of the gripper, and for initial gripping cycles. They are not designed for continuous operation.

- ① The scope of delivery includes two top jaws including fastening material. Observe the notes in the Assembly and Operating Manual of the EGH gripper.

## Flexible top jaw AUB-F EGH

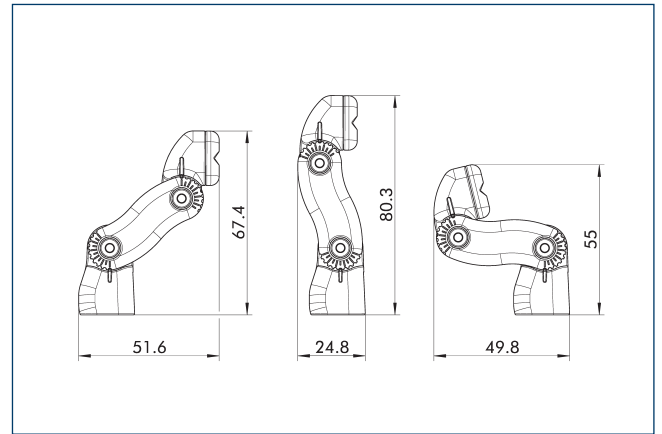

The flexible top jaws are specifically designed for the EGH gripper. The top jaws are mutually adjustable via two clampings in the clamping range. The drawing shows the achievable maximum values.

## Top jaw AUB EGH

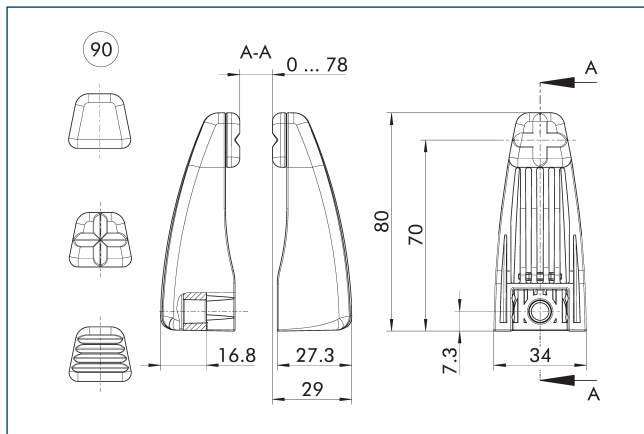

- 90 Finger inserts

The top jaws are specifically designed for the EGH gripper. Depending on the size, they are available with varying clamping ranges. Depending on the application and workpiece, one of the supplied finger inserts can be used. The finger inserts are manufactured from rigid or elastic material.

- ① The scope of delivery includes two top jaws including fastening material. Observe the notes in the Assembly and Operating Manual of the EGH gripper.



**SCHUNK GmbH & Co. KG**  
**Spann- und Greiftechnik**

Bahnhofstr. 106 - 134  
D-74348 Lauffen/Neckar  
Tel. +49-7133-103-0  
Fax +49-7133-103-2399  
info@de.schunk.com  
schunk.com

Follow us



*J. Lehmann*

Jens Lehmann, German goalkeeper legend, SCHUNK brand ambassador since 2012 for safe, precise gripping and holding.  
[schunk.com/Lehmann](https://schunk.com/Lehmann)