



LMI TECHNOLOGIES

Welcome to **FactorySmart**®



3D SMART SENSORS FOR FACTORY AUTOMATION

Meet **Gocator**.

Two trusted 3D technologies to automate your factory applications.



LASER PROFILERS

Gocator Point and Line Profile Sensors scan any **moving target** with height resolutions down to 1.1 μm and sampling speeds up to 32 kHz, while providing seamless communication with factory machinery and systems to deliver a complete automation solution.



SNAPSHOT SENSORS

Gocator Stereo Snapshot Sensors generate 3D shape and surface data with a single scan trigger. They are ideal for automated assembly using robot guidance, non-contact volume gauging, and a variety of process automation applications.

WELCOME TO **FACTORYSMART**[®] AUTOMATION

Gocator[®]

An easy-to-use, flexible design delivers high-performance machine vision with seamless data communication so your factory can operate more efficiently and profitably.

Easy to Use

Features such as a web-browser driven point-and-click environment for rapid configuration, built-in measurement tools, and rich I/O for communicating results make it easy for factory technicians to get the results they need.

Real-Time Data Processing for Inline Production

Real-time onboard processing capabilities minimize lag between data acquisition and decision outputs, which means factories can consistently meet their throughput targets.

Customizable

Sensor customization allows users to develop and embed custom measurement tools directly into the firmware itself—with the same functionality and ease-of-use as built-in native tools.

Connected

Connect seamlessly with factory infrastructure to report measurement results, monitor trends from a web browser, upgrade sensors over the Internet, or network with other machinery to exchange or combine data to achieve the best optimization results.

Robot-Friendly

Gocator offers built-in support to work with robots directly (e.g., Universal Robots) and enable a fully functional multi-model production line to work at a much faster, more efficient pace than traditional single-model assembly lines.

GOALS OF FACTORY AUTOMATION:

- » Increase productivity
- » Eliminate manual error
- » Improve quality and flexibility in the manufacturing process
- » Lower operating costs
- » Increase worker safety
- » Provide workers with the opportunity to assume new, higher value roles and responsibilities



MAKE MANUAL TASKS AUTOMATIC

Gocator works seamlessly with automation equipment and control systems (such as PLCs and robots) to provide vision guidance, 3D measurement, and downstream control decisions for factory automation applications.

PROCESS AUTOMATION



MANUFACTURING CONTROL



MATERIAL HANDLING AND STORAGE

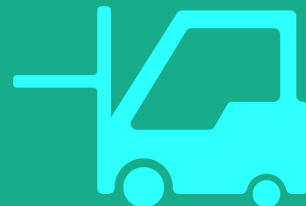

WHY SMART 3D?

- » Volumetric measurement (X, Y, and Z axis) provides shape and position related data—necessary for robot handling
- » Contrast invariant, ideal for inspecting low contrast objects
- » Immune to lighting variation and ambient light
- » Higher repeatability due to integrated optics, lighting, and pre-calibration

AUTOMATION EXAMPLES USING **Gocator**

Automated Cylinder Head Volume Gauging

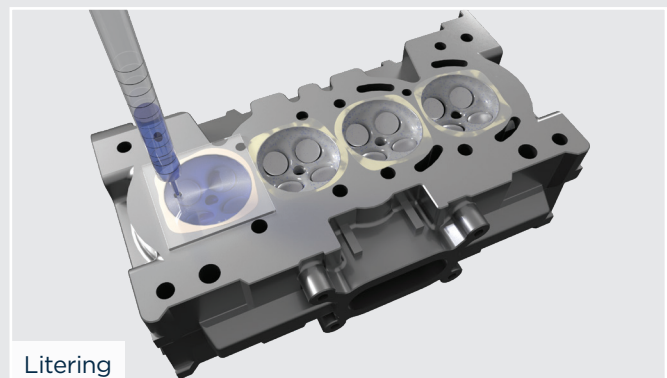
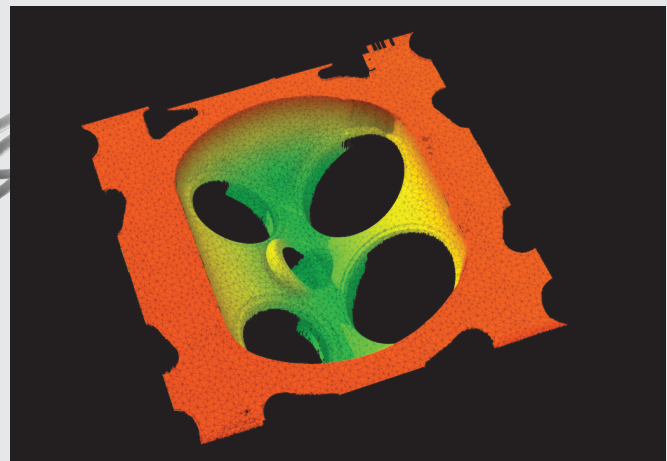
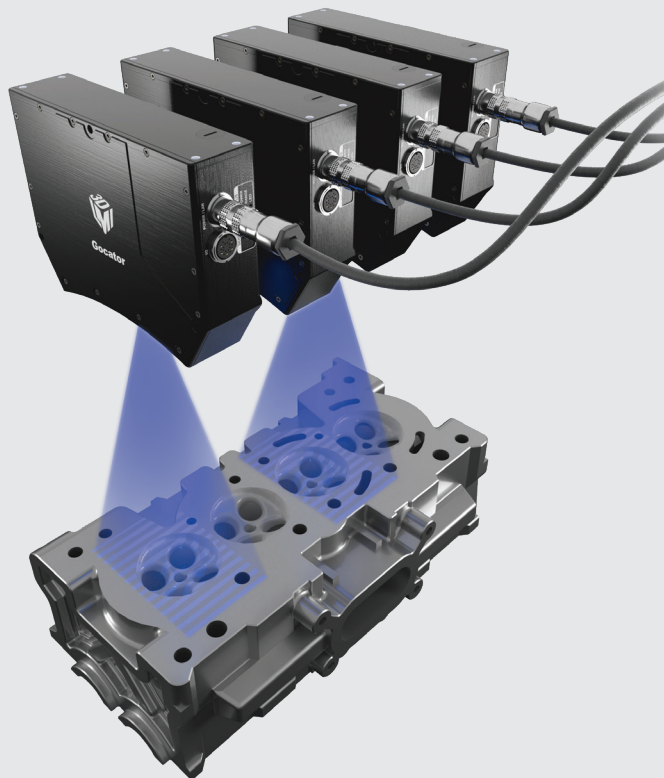

Litering

BENEFITS OF FACTORYSMART[®] AUTOMATION:

- » Automates traditionally manual processes
- » Increases speed, accuracy, and operational safety
- » Minimizes takt time and eliminates manual error
- » Saves time and labor costs

Traditional volume gauging is done with slow, error-prone, contact-based methods such as litering. Alternatively, Gocator Volume Checker provides a fully automated non-contact 3D solution that leverages multiple 3210 snapshot sensors and a built-in measurement algorithm. Volume Checker scans and calculates the volume of engine cylinder heads in under 5 seconds with an accuracy of $\pm 0.04 \text{ cm}^3$.

Automated Windshield/Roof Insertion

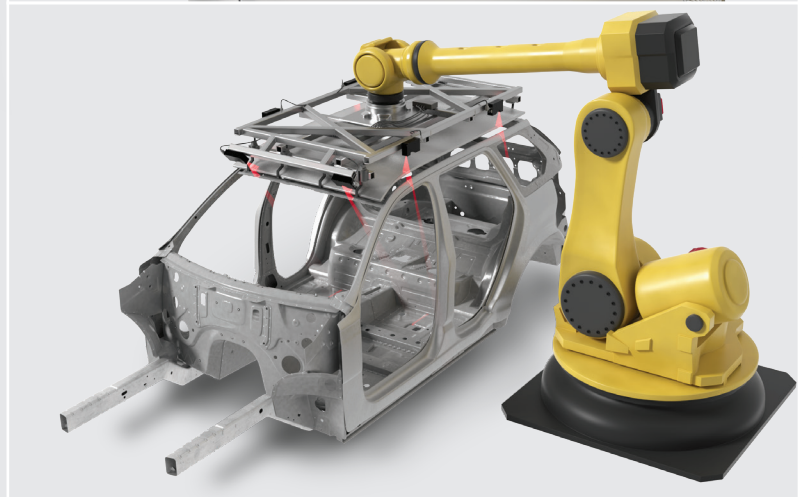
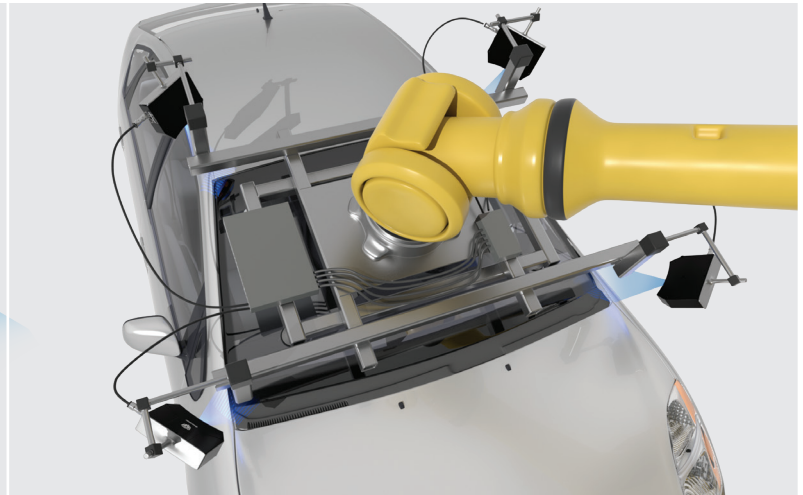
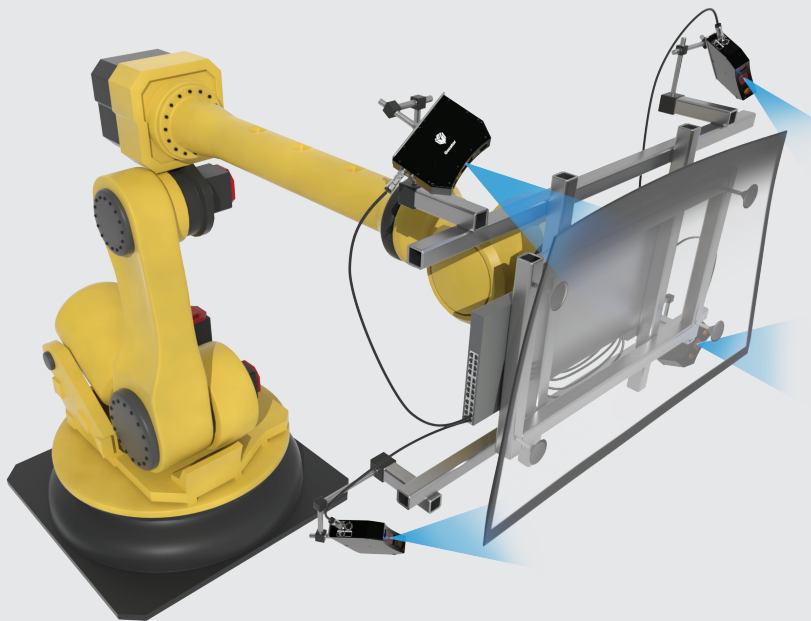

Gocator 3210 snapshot sensors guide a robot to accurately place and position a windshield or roof on a vehicle. This approach effectively replaces the labour-intensive manual approach of technicians using suction cups.

CASE STUDY: GOCATOR AND BLUEWRIST

LMI partner Bluewrist uses Gocator 2300 line profilers for vision-guidance in its windshield insertion system. These sensors seamlessly integrate with robot technology and automate a critical assembly process with a high degree of speed and accuracy.

AUTOMATION EXAMPLES USING **Gocator**

Automated Potato Sorting

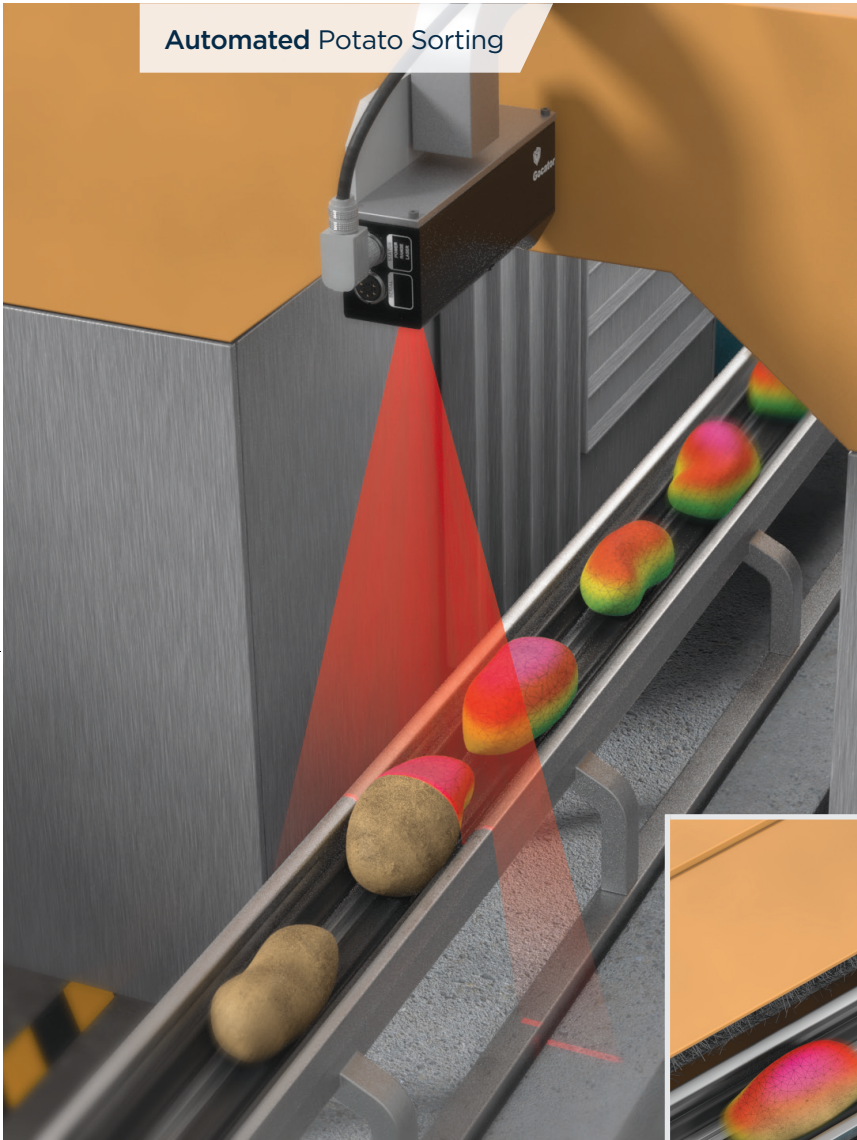

Gocator scans potatoes individually and grades them based on size, shape, and surface characteristics. Gocator then tags and tracks each potato and communicates a downstream control decision to a deflector that sorts the potatoes into the appropriate bins.

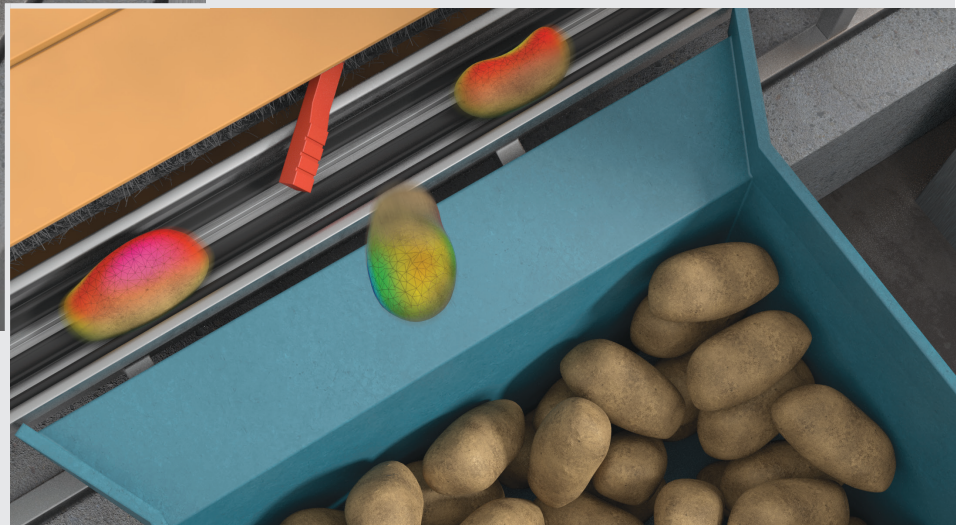

Automated Portioning

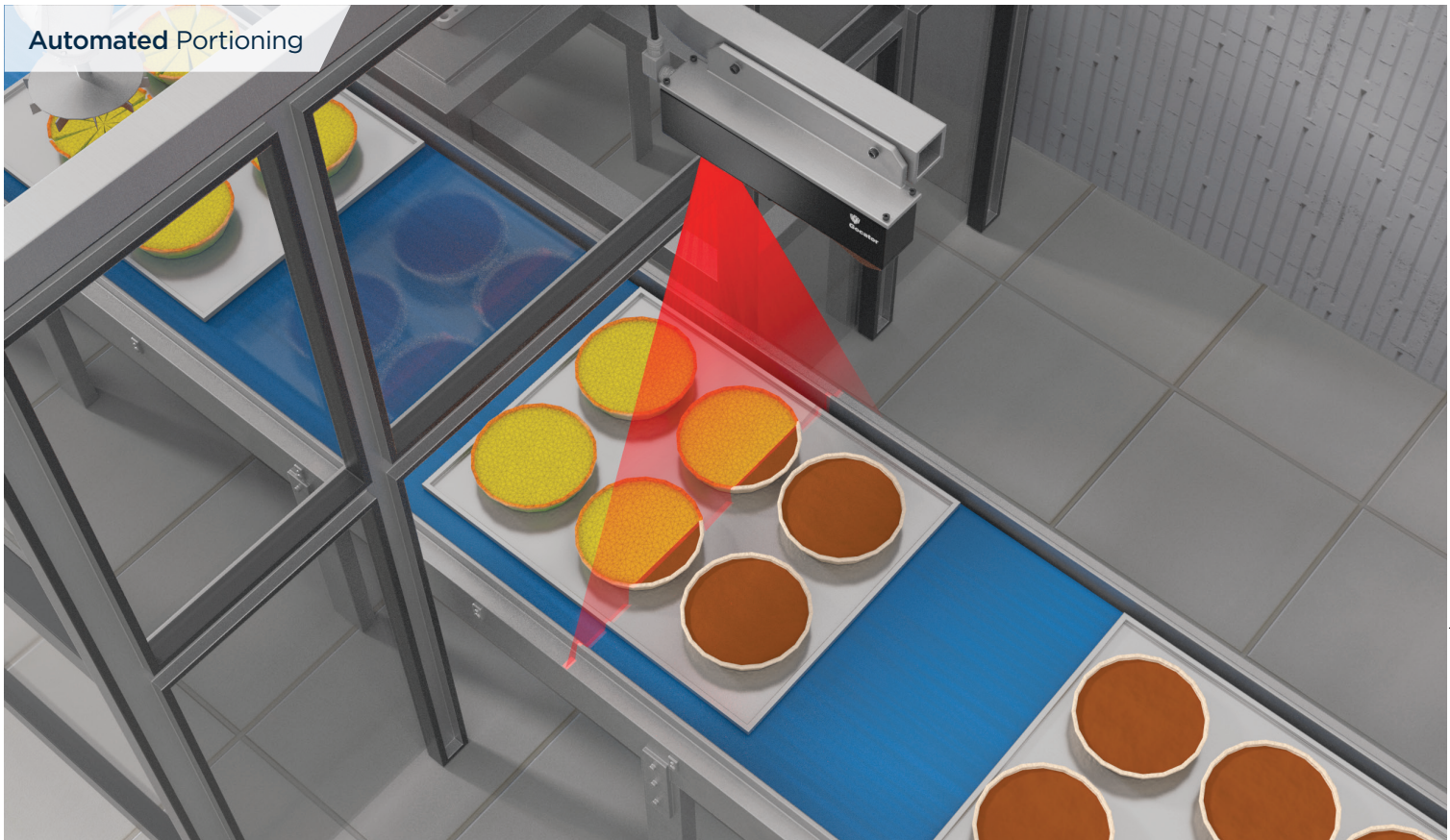

Gocator line profilers scan and locate the centerpoint of baked pies traveling on a conveyor. Sensors then communicate optimal cutlines to robotic slicers, which cut each pie into equal portions.

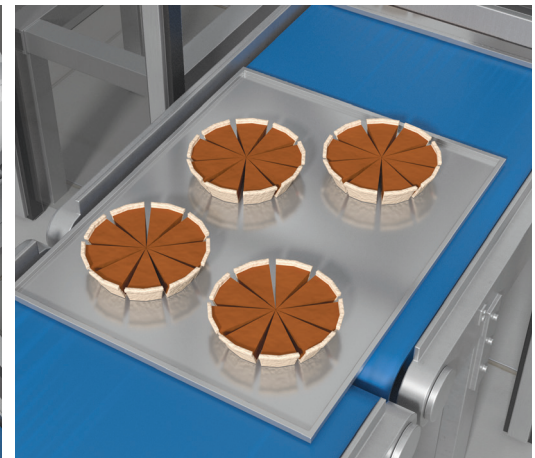

AUTOMATION EXAMPLES USING **Gocator**

Automated Pick-and-Place

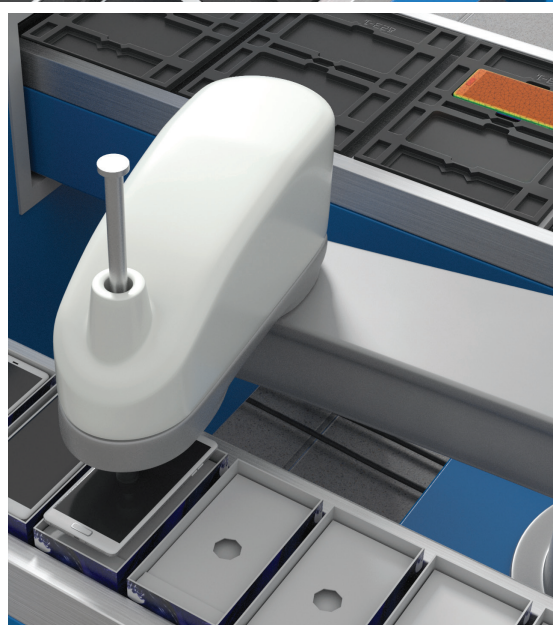
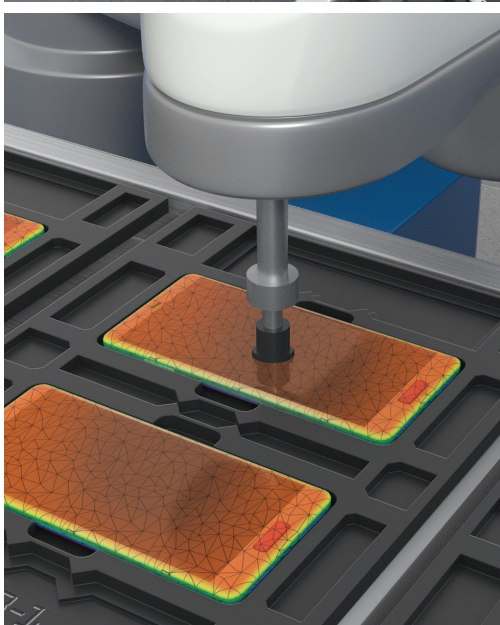
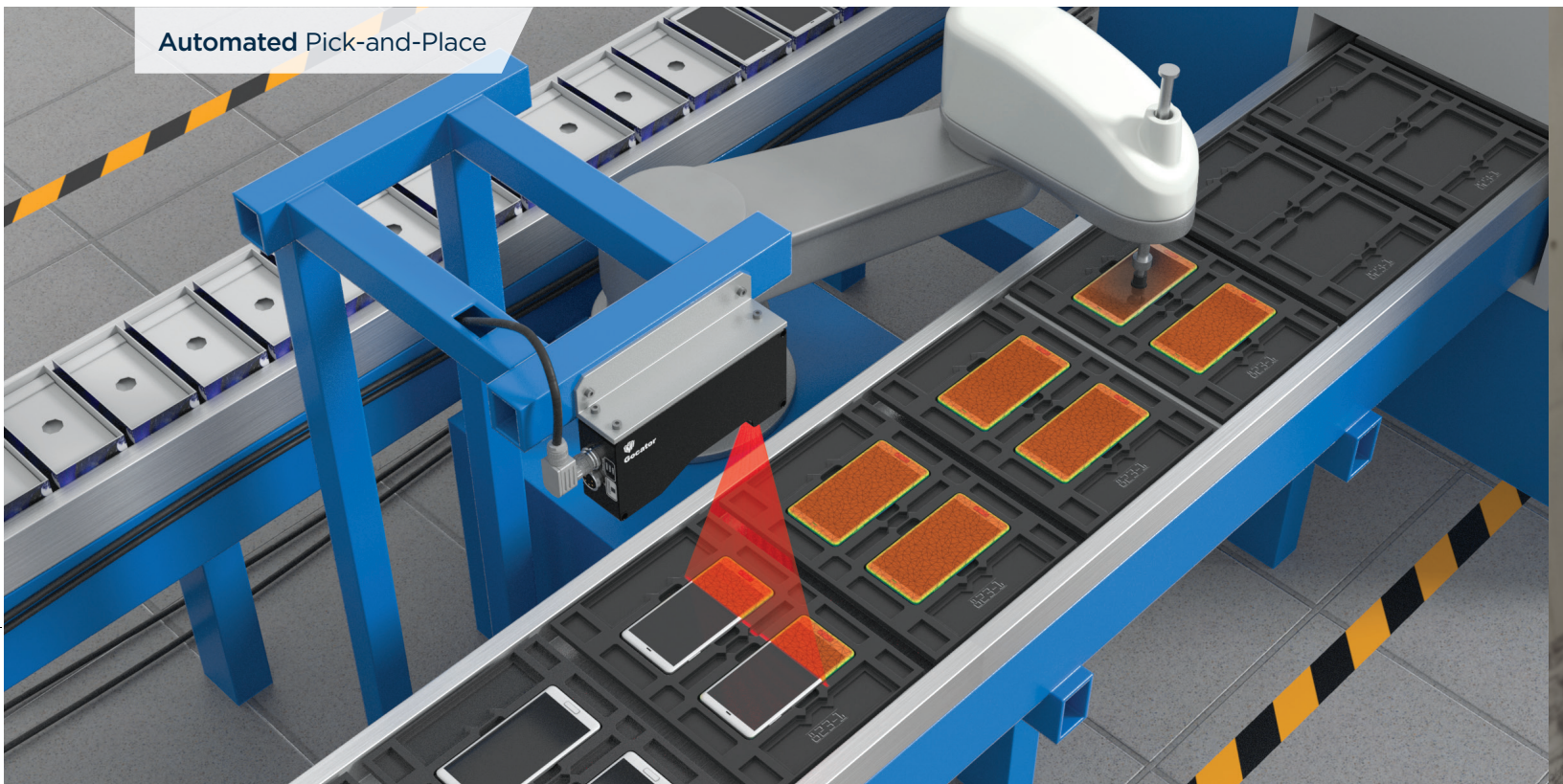

Gocator scans cellphones secured in plastic carriers moving down a conveyor. Once 3D data is acquired, Gocator communicates downstream to a robotic arm that picks up and places the phones in their packages based on the positional data provided by the sensor.

Automated Conveyor Belt Flow Control

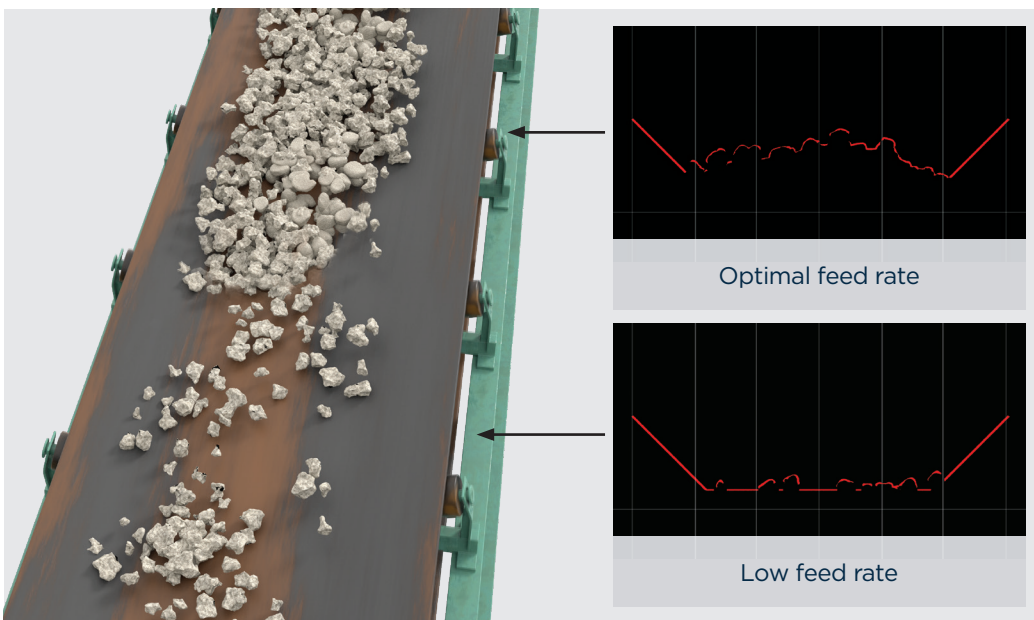
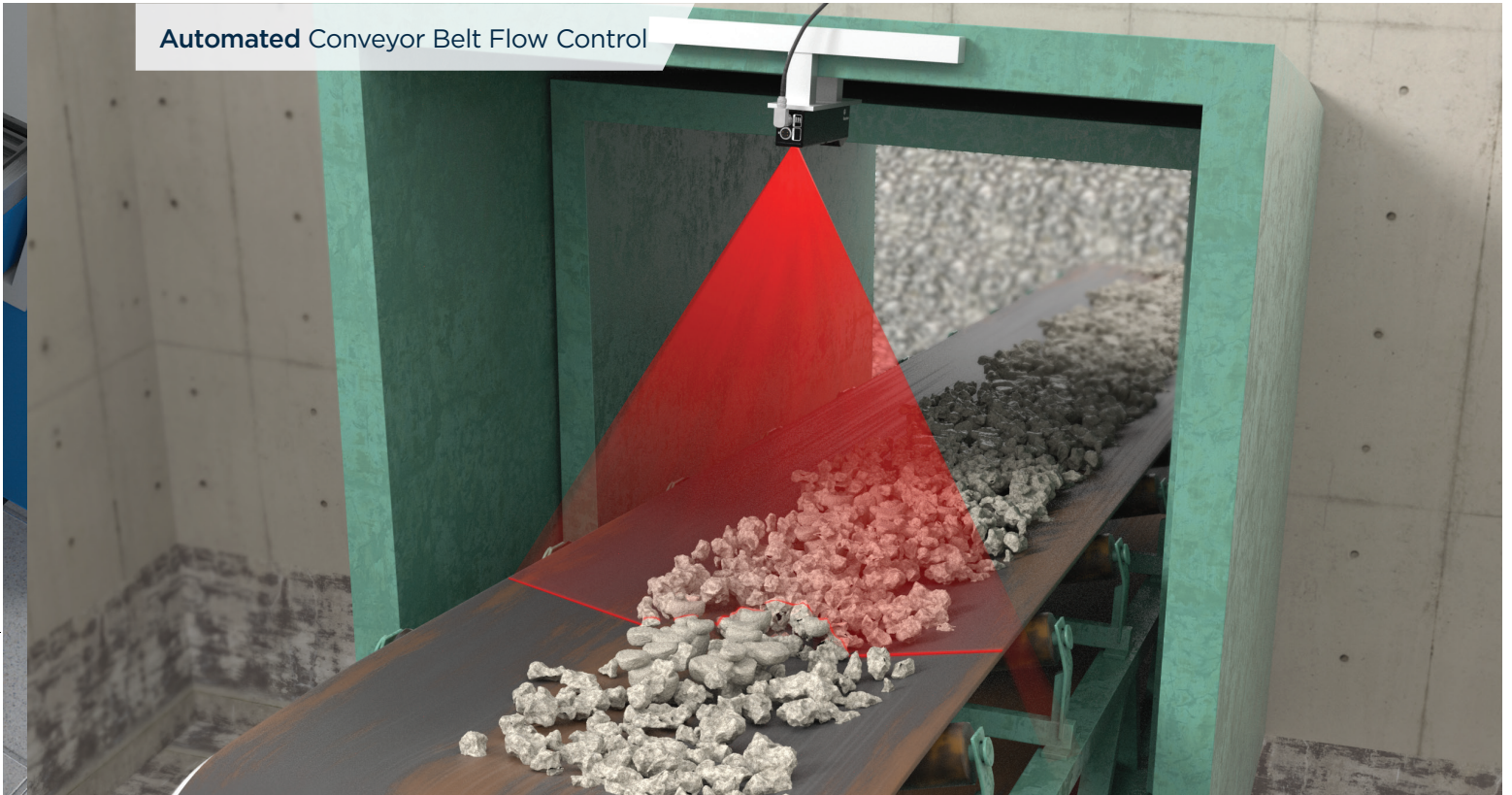

Gocator scans a conveyor belt to determine the volume of material (e.g. gravel) and its downstream feed rate.



AUTOMATION EXAMPLES USING **Gocator**

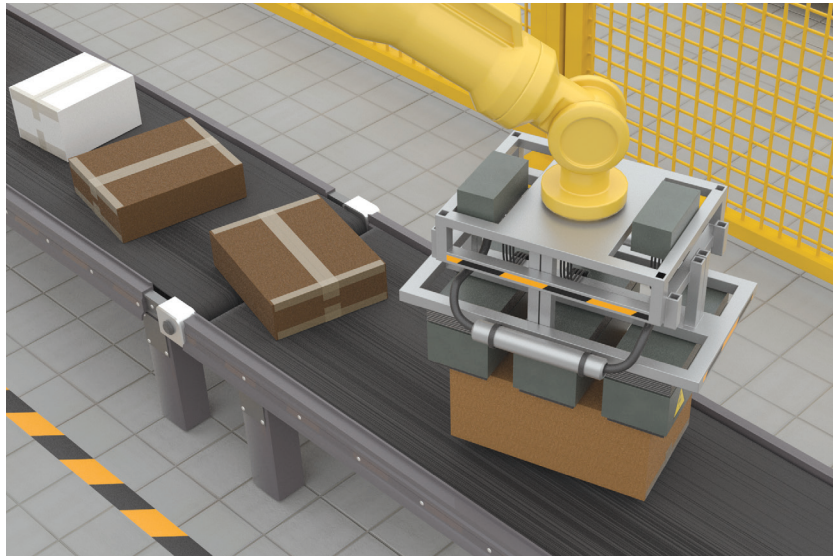
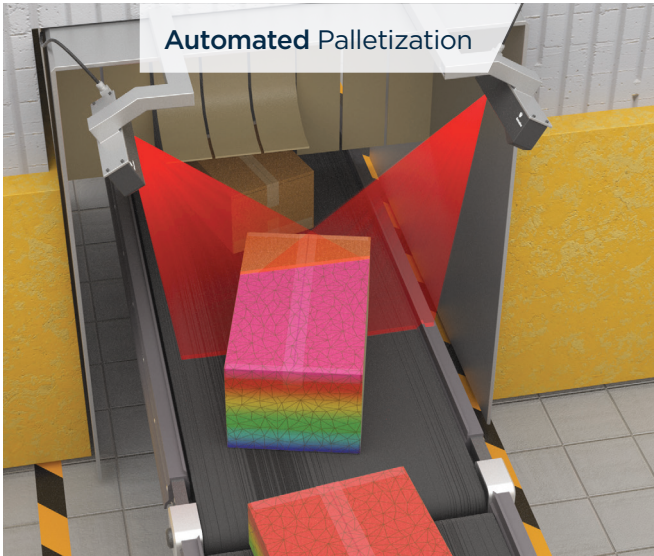

Automated De-Palletization

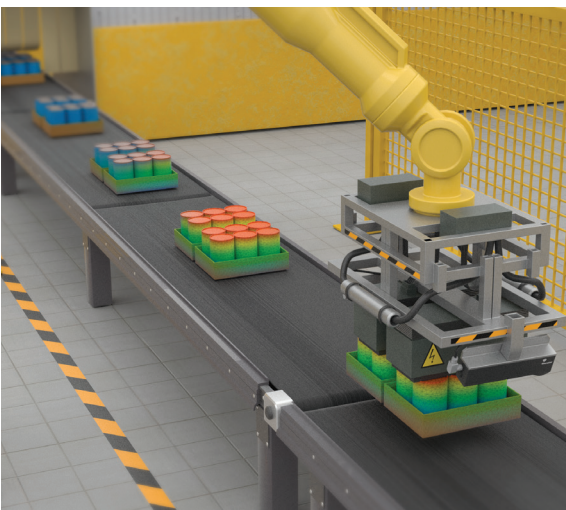
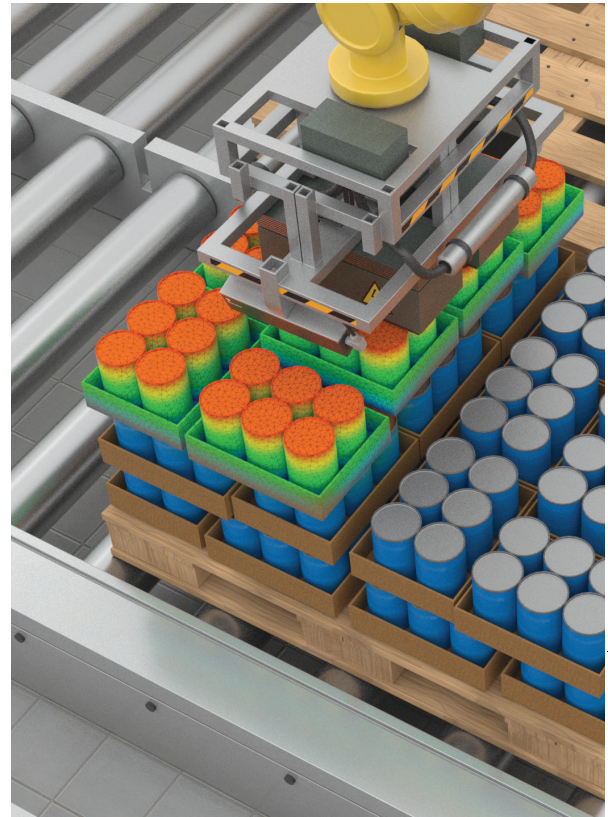
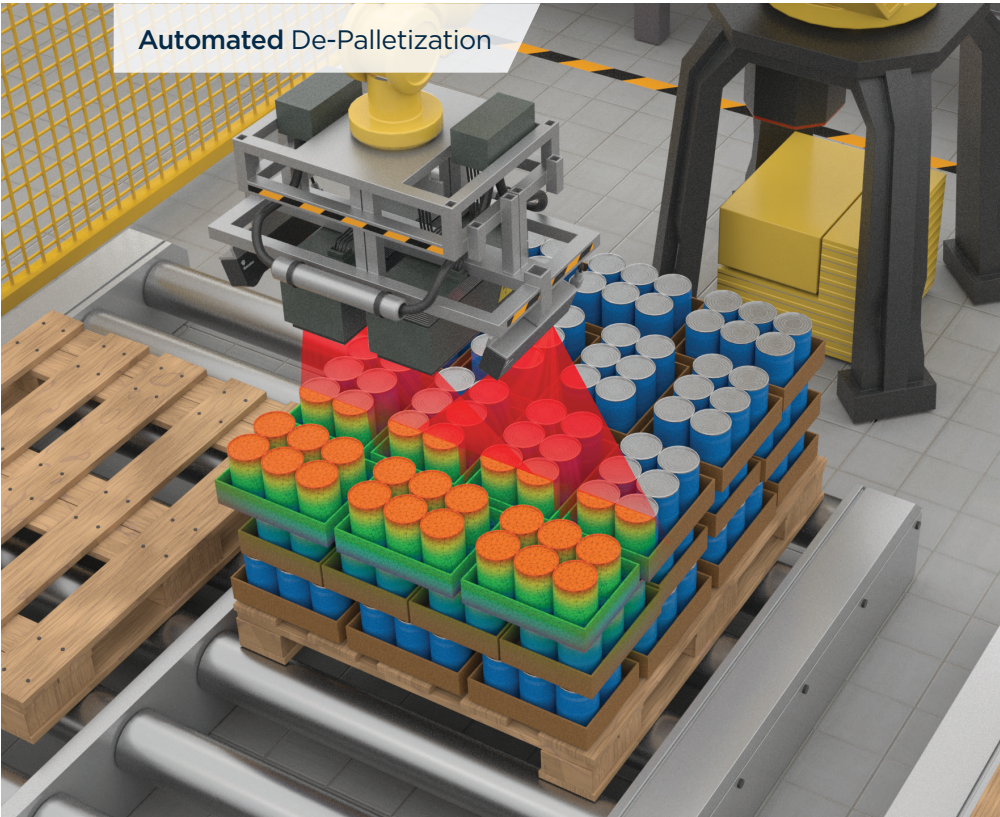

Two Gocator 2170 sensors (mounted to either side of a robotic loading arm) scan a loaded pallet. Before lifting the top row of boxes, the arm passes over the pallet to scan the row designated for removal. Gocator provides the arm with the precise positional coordinates to safely lift the boxes off of the pallet.

BENEFITS OF FACTORYSMART[®] AUTOMATION:

- » Easily integrates with factory equipment for complex guidance and assembly applications
- » Built-in measurement tools eliminate need for image analysis software development
- » Immune to robot movement and vibration

GOCATOR® SOFTWARE

FOR SMART 3D INSPECTION

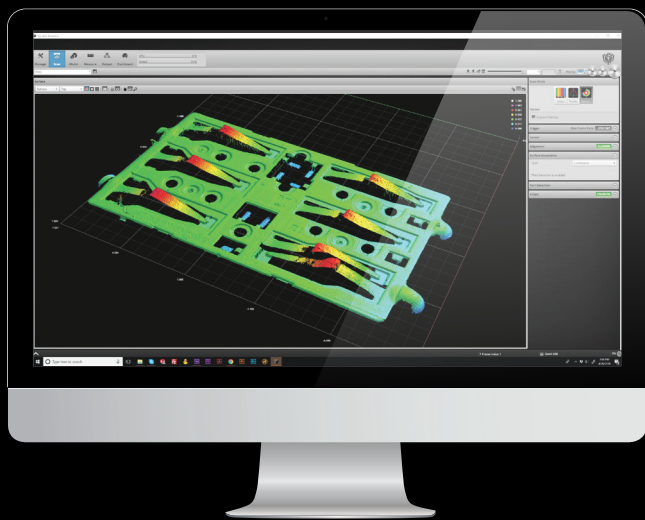

INTUITIVE AND EASY TO USE

- » Web browser based interface
- » OS independent (PC, Mac, Linux)
- » Point-and-click functionality
- » Firmware included, no separate software required
- » Process 2D intensity and 3D height data for high repeatability

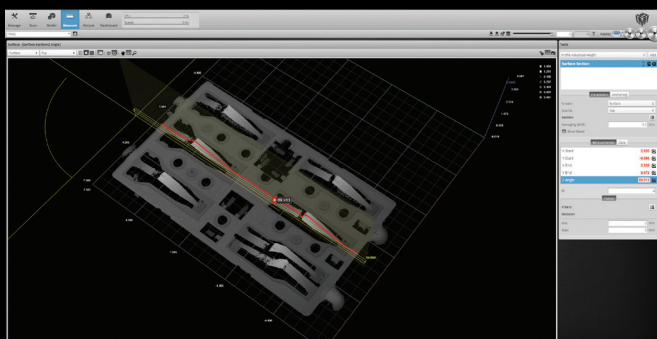

3D surface view with intensity data

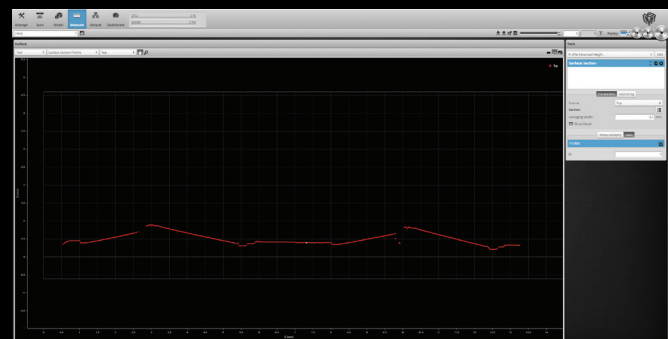

Profile view

BUILT INTO EVERY GOCATOR®

Instant access to scan, measure, and control

Real-time sensor feedback (including speed and CPU usage)

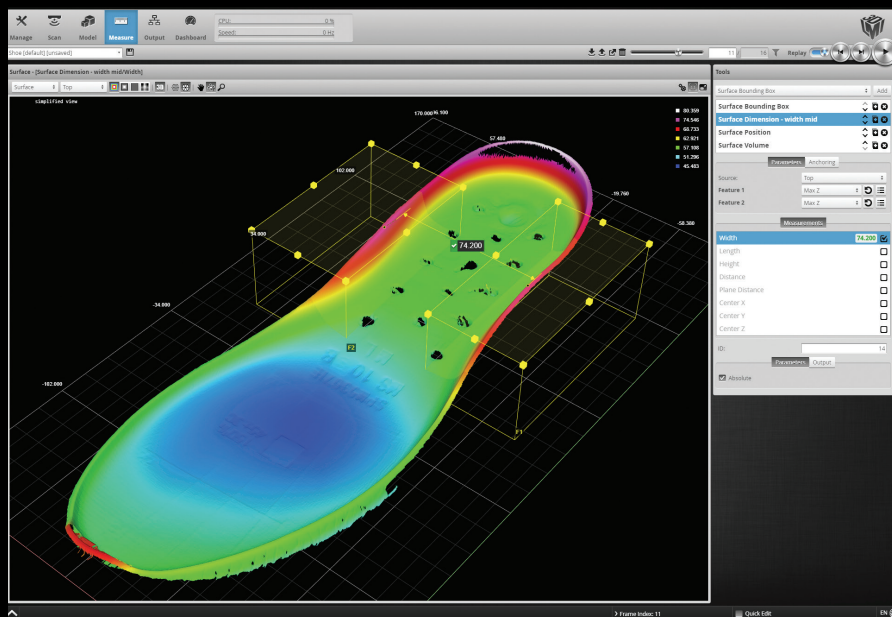

One-click toggling between Video, Profile, and Surface mode

Drag-and-drop measurement tools

Variety of formats for fast and accurate data output

Real-time, high-definition 3D Data Visualizer

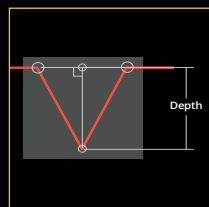

Groove Depth

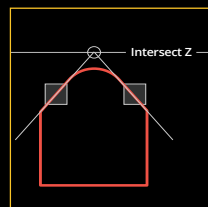

Intersect Z

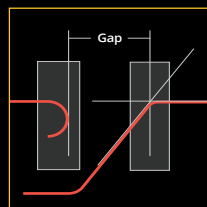

Gap & Flush

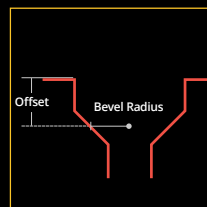

Countersunk Hole

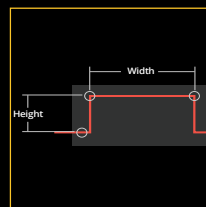

Strip Tool

140+ TOOLS
at your disposal

PRODUCT LINEUP

LASER PROFILE SENSORS



Gocator 1300 Series

High-speed (32 kHz) Point Profilers for Dimensional Measurements

- Unique built-in part detection and profile generation
- Ideal for closed loop control or measuring high speed processes



Gocator 2100 Series

Low Cost, Entry-Level Line Profilers for Basic Inline 3D Inspection

- Handles all of your basic quality inspection needs
- VGA imager, 640 points per profile resolution
- Field of view up to 1260 mm
- Measurement range up to 800 mm



Gocator 2300 Series

Workhorse Line Profilers for Robust Inline 3D Inspection

- Handles a wide range of applications
- Megapixel imager, 1280 points per profile resolution
- Field of view up to 1260 mm
- Measurement range up to 800 mm



Gocator 2400 Series

Ultra High-Resolution Line Profilers for Advanced Inline 3D Inspection

- Handles difficult targets such as micro-features on small parts in high-speed applications
- 2-Megapixel imager, up to 1940 points per profile resolution
- Field of view up to 194 mm
- Measurement range up to 210 mm



Gocator 2500 Series

Ultra High-Speed Line Profilers for Small Parts 3D Inspection

- Ideal for fast-moving inline inspection systems
- 2-Megapixel imager. Up to 1920 points per profile resolution
- Scan, measurement, and control at up to 10 kHz
- Field-of-view up to 33.5 mm
- Measurement range up to 25 mm



Gocator 2880

Dual Triangulation Line Profilers for 3D Inspection of Large Objects

- Two cameras maximize scan coverage and minimize occlusions for applications such as primary log scanning
- Megapixel imager, 1280 points per profile resolution
- Field of view up to 1260 mm
- Measurement range up to 800 mm



Gocator 3504

Metrology-grade 6.7 μm Sensor for Small Parts Inspection

- For applications such as connector and pin coplanarity, wire detection, surface flatness, and stent inspection
- Fast scan rate (6 Hz full-field)
- XY resolution down to 6.7 μm
- Z repeatability down to 0.2 μm

Gocator 3506

Metrology-grade 12 μm Sensor for Small Parts Inspection

- Detect fine features on small parts such as electronic enclosures, PCB and battery/IC connectors
- Fast scan rate (3 Hz full-field)
- 5-megapixel stereo camera minimizes occlusions
- High repeatability (2 μm) for reliable measurements at production speed

Gocator 3210

Metrology-grade 35 μm Sensor for Large Parts Inspection

- Detect features on large objects such as automotive cylinders
- Fast scan rate (4 Hz full-field)
- 2-megapixel stereo camera minimizes occlusions
- Wide field of view up to 154 mm

TEST DRIVE A GOCATOR® SENSOR

Choose from a variety of application scenarios, then use an exact duplicate of the Gocator interface. Perform measurements on pre-recorded data from a variety of scanned components—all in a web browser-based "virtual sensor" environment. Right from your desktop. Without the need for a physical sensor.

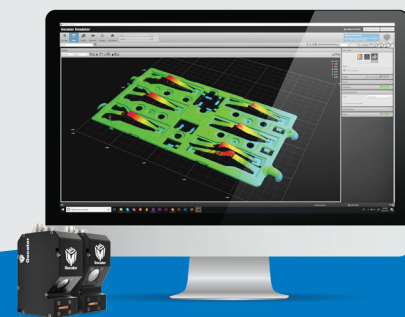

Take Gocator® for a test drive today. Visit www.lmi3d.com/emulator

PRODUCT SPECS

Gocator 1300 Series		Laser Point Profile					
MODELS	1320	1340	1350	1365	1370	1380	1390
Clearance Distance (mm)	40	162.5	200	562	237.5	127	500
Measurement Range (mm)	20	95	200	375	412.5	1651	2000
Linearity Z (+/- % of MR)	0.05	0.05	0.05	0.11	0.07	0.18	0.1
Linearity Z (+/- mm)	0.01	0.05	0.1	0.4	0.3	3.0	2.0
Resolution Z (mm)	0.0004 - 0.0004	0.0005 - 0.0010	0.0015 - 0.0035	0.0025 - 0.0040	0.0025 - 0.0070	0.0100 - 0.0450	0.0250 - 0.0600
Spot Size (mm)	0.11	0.37	0.50	1.80	0.90	2.60	2.60
Recommended Package Dimensions (mm)	Side Mount (3R) 30x120x149	Side Mount 30x120x149	Side Mount 30x120x149	Side Mount 30x120x220	Side Mount (3B) 30x120x149	Side Mount 30x120x149	Side Mount 30x120x277
Other Package Dimensions (mm)	Top Mount (3B) 49x75x162		Top Mount 49x75x162		Top Mount (2M) 49x75x162		
Weight (kg)	0.75 / 0.8	0.75	0.75 / 0.8	1.0	0.75 / 0.8	0.75	1.25

Resolution Z based on averaging 128 samples. Optical models, laser classes, and packages can be customized. Contact LMI for more details. Specifications stated are based on standard laser classes. Resolution Z and Linearity Z may vary for other laser classes. Refer to specifications in the Gocator Point Profile Sensor user manual for more details.

ALL 1300 SERIES MODELS	
Scan Rate (Hz)	32,000
Interface	Gigabit Ethernet
Inputs	Differential Encoder, Laser Safety Enable, Trigger
Outputs	2x Digital Output, RS-485 Serial, Selcom Serial, 1x Analog Output (4-20mA)
Input Voltage (Power)	+24 to +48 VDC (13 Watts); Ripple +/- 10%
Housing	Gasketed aluminum enclosure, IP67
Operating Temperature	0 to 50 °C
Storage Temperature	-30 to 70 °C
Vibration Resistance	10 to 55 Hz, 1.5 mm double amplitude in X, Y, and Z directions, 2 hours per direction
Shock Resistance	15 g, half sine wave, 11 ms, positive and negative for X, Y, and Z directions
Scanning Software	Browser-based GUI and open source SDK for configuration and real-time 3D visualization. Open source SDK, native drivers, and industrial protocols for integration with user applications, third-party image processing applications, and PLCs.

Gocator 2100 Series		Laser Line Profile					
MODELS	2120	2130	2140	2150	2170	2175	2180
Data Points / Profile	640	640	640	640	640	640	640
Linearity Z (+/- % of MR)	0.01	0.01	0.01	0.01	0.04	0.03	0.04
Resolution Z (mm)	0.0018-0.0030	0.006 - 0.014	0.013 - 0.037	0.019 - 0.060	0.055 - 0.200	0.175 - 0.925	0.092 - 0.488
Resolution X (mm) (Profile Data Interval)	0.028-0.042	0.088 - 0.150	0.19 - 0.34	0.3 - 0.6	0.55 - 1.10	0.51 - 1.58	0.75 - 2.20
Repeatability Z (µm)	0.4	0.8	1.2	2	8	12	12
Clearance Distance (CD) (mm)	40	90	190	300	400	650	350
Measurement Range (MR) (mm)	25	80	210	400	500	1350	800
Field of View (FOV) (mm)	18 - 26	47 - 85	96 - 194	158 - 365	308 - 687	324 - 1010	390 - 1260
Dimensions (mm)	Side Mount 35x120x149.5	Top Mount 49x75x142	Top Mount 49x75x197	Top Mount 49x75x272	Top Mount 49x75x272	Top Mount 49x75x272	Top Mount 49x75x272
Weight (kg)	0.8	0.74	0.94	1.3	1.3	1.3	1.3

Optical models, laser classes, and packages can be customized. Contact LMI for more details. Specifications stated are based on standard laser classes. Linearity Z, Resolution Z, and Repeatability Z may vary for other laser classes. Refer to specifications in the Gocator Line Profile Sensor user manual for more details.

ALL 2100 SERIES MODELS	
Scan Rate	Approximately 170 Hz to 5000 Hz
Interface	Gigabit Ethernet
Inputs	Differential Encoder, Laser Safety Enable, Trigger
Outputs	2x Digital output, RS-485 Serial (115 kBaud), 1x Analog Output (4 - 20 mA)
Input Voltage (Power)	+24 to +48 VDC (13 Watts); Ripple +/- 10%
Housing	Gasketed aluminum enclosure, IP67
Operating Temperature	0 to 50°C
Storage Temperature	-30 to 70°C
Vibration Resistance	10 to 55 Hz, 1.5 mm double amplitude in X, Y, and Z directions, 2 hours per direction
Shock Resistance	15 g, half sine wave, 11 ms, positive and negative for X, Y, and Z directions
Scanning Software	Browser-based GUI and open source SDK for configuration and real-time 3D visualization. Open source SDK, native drivers, and industrial protocols for integration with user applications, third-party image processing applications, and PLCs.

LASER PROFILE SENSORS

Gocator 2300 Series

Laser Line Profile

MODELS	2320	2330	2340	2350	2370	2375	2380
Data Points / Profile	1280	1280	1280	1280	1280	1280	1280
Linearity Z (+/- % of MR)	0.01	0.01	0.01	0.01	0.04	0.03	0.04
Resolution Z (mm)	0.0018 - 0.0030	0.006 - 0.014	0.013 - 0.037	0.019 - 0.060	0.055 - 0.200	0.175 - 0.925	0.092 - 0.488
Resolution X (mm) (Profile Data Interval)	0.014 - 0.021	0.044 - 0.075	0.095 - 0.170	0.150 - 0.300	0.275 - 0.550	0.255 - 0.790	0.375 - 1.100
Repeatability Z (µm)	0.4	0.8	1.2	2	8	12	12
Clearance Distance (CD) (mm)	40	90	190	300	400	650	350
Measurement Range (MR) (mm)	25	80	210	400	500	1350	800
Field of View (FOV) (mm)	18 - 26	47 - 85	96 - 194	158 - 365	308 - 687	324 - 1010	390 - 1260
Dimensions (mm)	Side Mount 35x120x149.5	Top Mount 49x75x142	Top Mount 49x75x197	Top Mount 49x75x272	Top Mount 49x75x272	Top Mount 49x75x272	Top Mount 49x75x272
Weight (kg)	0.8	0.74	0.94	1.3	1.3	1.3	1.3

Optical models, laser classes, and packages can be customized. Contact LMI for more details. Specifications stated are based on standard laser classes. Linearity Z, Resolution Z, and Repeatability Z may vary for other laser classes. Refer to specifications in the Gocator Line Profile Sensor user manual for more details.

ALL 2300 SERIES MODELS

Scan Rate	Approximately 170 Hz to 5000 Hz
Interface	Gigabit Ethernet
Inputs	Differential Encoder, Laser Safety Enable, Trigger
Outputs	2x Digital output, RS-485 Serial (115 kBaud), 1x Analog Output (4 - 20 mA)
Input Voltage (Power)	+24 to +48 VDC (13 Watts); Ripple +/- 10%
Housing	Gasketed aluminum enclosure, IP67
Operating Temperature	0 to 50°C
Storage Temperature	-30 to 70°C
Vibration Resistance	10 to 55 Hz, 1.5 mm double amplitude in X, Y, and Z directions, 2 hours per direction
Shock Resistance	15 g, half sine wave, 11 ms, positive and negative for X, Y, and Z directions
Scanning Software	Browser-based GUI and open source SDK for configuration and real-time 3D visualization. Open source SDK, native drivers, and industrial protocols for integration with user applications, third-party image processing applications, and PLCs.

Gocator 2400 Series

Laser Line Profile

MODELS	2410	2420	2430	2440
Data Points / Profile	1710	1940	1500	1500
Linearity Z (+/- % of MR)	0.015	0.006	0.01	0.01
Resolution Z (µm)	1.1	1.8 - 3.0	6 - 14	13 - 37
Resolution X (µm) (Profile Data Interval)	5.8 - 6.2	14.0 - 16.5	37 - 57	90 - 130
Repeatability Z (µm)	0.2	0.4	0.8	1.2
Clearance Distance (CD) (mm)	19.0	60.0	75	183
Measurement Range (MR) (mm)	6.0	25.0	80	210
Field of View (FOV) (mm)	10.0 - 10.0	27.0 - 32.0	47 - 85	96 - 194
Dimensions (mm)	44x90x145	44x90x145	44x90x155	44x90x190
Weight (kg)	0.88	0.88	1.0	1.2

Optical models, laser classes, and packages can be customized. Contact LMI for more details. Specifications stated are based on Recommended laser classes. Linearity Z, Resolution Z, and Repeatability Z may vary for other laser classes.

ALL 2400 SERIES MODELS

Scan Rate	200 Hz, up to 5 kHz. (Note: 2400 series provide up to 2x scan rate for equivalent window size as 2300 series)
Interface	Gigabit Ethernet
Inputs	Differential Encoder, Laser Safety Enable, Trigger
Outputs	2x Digital output, RS-485 Serial (115 kBaud), 1x Analog Output (4 - 20 mA)
Input Voltage (Power)	+24 to +48 VDC (9 Watts); Ripple +/- 10%
Housing	Gasketed aluminum enclosure, IP67
Operating Temperature	0 to 50°C
Storage Temperature	-30 to 70°C
Vibration Resistance	10 to 55 Hz, 1.5 mm double amplitude in X, Y, and Z directions, 2 hours per direction
Shock Resistance	15 g, half sine wave, 11 ms, positive and negative for X, Y, and Z directions
Scanning Software	Browser-based GUI and open source SDK for configuration and real-time 3D visualization. Open source SDK, native drivers, and industrial protocols for integration with user applications, third-party image processing applications, and PLCs.

PRODUCT SPECS

LASER PROFILE SENSORS

Gocator 2500 Series

Laser Line Profile

MODELS	2510	2512	2520
Data Points / Profile	1920	1920	1920
Linearity Z (+/- % of MR)	0.015	0.015	0.006
Resolution X (µm) (Profile Data Interval)	8.0	8.0	13.0 - 17.0
Repeatability Z (µm)	0.2	0.2	0.4
Clearance Distance (CD) (mm)	17.0	17.0	47.5
Measurement Range (MR) (mm)	6	6	25
Field of View (FOV) (mm)	13.0 - 14.5	13.0 - 14.5 (diffuse & specular)	25.0 - 32.5
Dimensions (mm)	46x80x110	46x80 x110	46x80x110
Weight (kg)	0.65	0.65	0.65

Optical models, laser classes, and packages can be customized. Contact LMI for more details. Specifications stated are based on Recommended laser classes. Linearity Z and Repeatability Z may vary for other laser classes.

ALL 2500 SERIES MODELS

Scan Rate	2.4 kHz (2510 full field of view) / 1.6 kHz (2520 full field of view) to 10 kHz
Interface	Gigabit Ethernet
Inputs	Differential Encoder, Laser Safety Enable, Trigger
Outputs	2x Digital output, RS-485 Serial (115 kBAud)
Input Voltage (Power)	+24 to +48 VDC (15 Watts); Ripple +/- 10%
Housing	Gasketed aluminum enclosure, IP67
Operating Temperature	0 to 40°C
Storage Temperature	-30 to 70°C
Vibration Resistance	10 to 55 Hz, 1.5 mm double amplitude in X, Y, and Z directions, 2 hours per direction
Shock Resistance	15 g, half sine wave, 11 ms, positive and negative for X, Y, and Z directions
Scanning Software	Browser-based GUI and open source SDK for configuration and real-time 3D visualization. Open source SDK, native drivers, and industrial protocols for integration with user applications, third-party image processing applications, and PLCs.

Gocator 2800 Series

Line Profile

MODELS	2880
Data Points / Profile	1280
Linearity Z (+/- % of MR)	0.04
Resolution Z (mm)	0.092 - 0.488
Resolution X (mm) (Profile Data Interval)	0.375 - 1.100
Clearance Distance (CD) (mm)	350
Measurement Range (MR) (mm)	800
Field of View (FOV) (mm)	390 - 1260
Dimensions (mm)	49x75x498
Weight (kg)	2.56
Scan Rate	380 Hz - 2500 Hz
Interface	Gigabit Ethernet
Inputs	Differential Encoder, Laser Safety Enable, Trigger
Outputs	2x Digital output, RS-485 Serial (115 kBAud), 1x Analog Output (4 - 20 mA)
Input Voltage (Power)	+24 to +48 VDC (13 Watts); Ripple +/- 10%
Housing	Gasketed aluminum enclosure, IP67
Operating Temperature	0 to 50°C
Storage Temperature	-30 to 70°C
Vibration Resistance	10 to 55 Hz, 1.5 mm double amplitude in X, Y and Z directions, 2 hours per direction
Shock Resistance	15 g, half sine wave, 11 ms, positive and negative for X, Y, and Z directions
Scanning Software	Browser-based GUI and open source SDK for configuration and real-time 3D visualization. Open source SDK, native drivers, and industrial protocols for integration with user applications, third-party image processing applications, and PLCs.

SNAPSHOT SENSORS

Gocator 3000 Series

Structured Light

MODELS	3504	3506	3210
Scan Rate (Hz)	6	3	4
Imagers (megapixels)	5	5	2
Clearance Distance (CD) (mm)	51.5	87.0	164.0
Measurement Range (MR) (mm)	7	25.0	110.0
Field of View (mm)	12.1 x 13.2 (near) 12.7 x 16.4 (maxY) 13.0 x 15.0 (far)	27.0 x 45.0 (near) 30.0 x 45.0 (far)	71.0 x 98.0 (near) 100.0 x 154.0 (far)
Repeatability Z (µm)	0.2	2.0	4.7
Resolution XY (mm)	0.0067 (close end) - 0.0071 (far end)	0.020 (close end) - 0.025 (far end)	0.060 (close end) - 0.090 (far end)
Dimensions (mm)	49x152x177.5	49x136x170	49x146x190
Weight (kg)	1.77	1.52	1.7
Light Source	Blue LED (465 nm)	Blue LED (465 nm)	Blue LED (465 nm)
Interface	Gigabit Ethernet	Gigabit Ethernet	Gigabit Ethernet
Inputs	Differential Encoder, Trigger	Differential Encoder, Trigger	Differential Encoder, Trigger
Outputs	2x Digital Output, RS485 Serial (115 kbaud), 1x Analog Output (4 - 20 mA)	2x Digital Output, RS485 Serial (115 kbaud), 1x Analog Output (4 - 20 mA)	2x Digital Output, RS485 Serial (115 kbaud), 1x Analog Output (4 - 20 mA)
Input Voltage (Power)	+24 to +48 VDC (25 Watts); Ripple +/- 10%	+24 to +48 VDC (25 Watts); Ripple +/- 10%	+24 to +48 VDC (50 Watts); Ripple +/- 10%
Housing	Gasketed Aluminium Enclosure, IP67	Gasketed aluminum enclosure, IP67	Gasketed aluminum enclosure, IP67
Operating Temperature	0 to 50 °C	0 to 50 °C	0 to 45 °C
Storage Temperature	-30 to 70 °C	-30 to 70 °C	-30 to 70 °C
Vibration Resistance	10 to 55 Hz, 1.5 mm double amplitude in X, Y, and Z directions, 2 hours per direction	10 to 55 Hz, 1.5 mm double amplitude in X, Y, and Z directions, 2 hours per direction	10 to 55 Hz, 1.5 mm double amplitude in X, Y, and Z directions, 2 hours per direction
Shock Resistance	15 g, half sine wave, 11 ms, positive and negative for X, Y, and Z directions	15 g, half sine wave, 11 ms, positive and negative for X, Y and Z directions	15 g, half sine wave, 11 ms, positive and negative for X, Y and Z directions
SOFTWARE AND BUILT-IN 3D MEASUREMENT TOOLS			
3D Feature Tools	Openings (holes, slots), Cylinders, Studs (threaded and non-threaded), Plane		
3D Volumetric Tools	Volumes, Areas, Bounding boxes, Positions (min, max, centroid), Ellipses, Orientations		
Scanning Software	Browser-based GUI and open source SDK for configuration and real-time 3D visualization. Open source SDK, native drivers, and industrial protocols for integration with user applications, third-party image processing applications, and PLCs.		

FIND YOUR SENSOR. FASTER.

Need some help finding the right Gocator® for your application? No problem. Simply visit our dedicated Product Selector, enter a few details about your application, and the Selector will automatically generate a list of suitable sensor models for you to explore.



Try the Product Selector today. Visit www.lmi3d.com/selector

GoMax. SMART VISION ACCELERATOR



GoMax® provides a cost-effective hardware solution to accelerate any Gocator® sensor in order to meet inline production speed. GoMax's small form factor, dedicated data processing, continuous data feed over Ethernet, and automatic recovery from inspection errors allow engineers to replace industrial PCs.

With GoMax's plug and play functionality, you can quickly and easily add massive data processing power to your Gocator® sensor or multi-sensor network, achieving faster cycle times and enhancing overall inspection performance.

- » Data processing acceleration with no industrial PC or controller
- » Plug and play functionality, easy integration
- » Simultaneously accelerate multiple Gocator smart sensors
- » Add multiple GoMax® units as needed

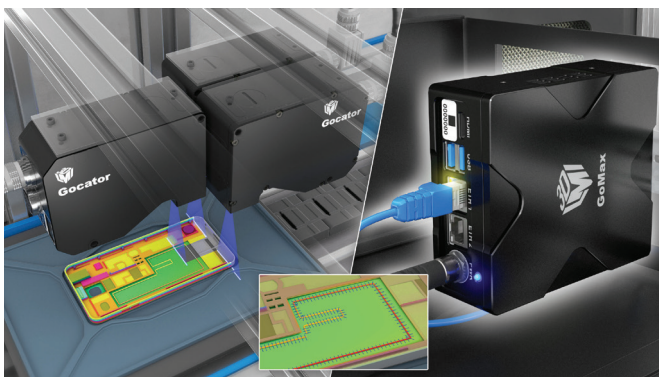

GoMax	Smart Vision Accelerator
Carrier Board	Jetson TX2
CPU	64-bit Quad ARM A57 @ 2 GHz plus 64-bit Dual Denver 2 @ 2 GHz
GPU	NVIDIA Pascal, 256 CUDA cores
Memory	8 GB 128-bit LPDDR4
IO ports	1x USB3, 1x HDMI, 2x GigE, 1x USB2
Dimensions (mm)	120x105x43.5
Weight (kg)	0.7
Operating Temperature	0 to 50 °C

SENSOR NETWORKING FOR SCANNING LARGE OBJECTS

Gocator laser profilers support seamless multi-sensor networking for scanning large or complex objects (i.e., with irregular surface geometry and multiple occlusions). These sensor networks are connected by LMI Master controllers.

MASTER 810 & 2410

Master 810 and 2410 network controllers make it easy to distribute power, achieve microsecond data synchronization, and provide laser safety for up to 24 sensors per Master. Designed to scale, Masters provide uplink/download ports for daisy chaining, and support differential or single-ended encoder and digital I/O.

- » Synchronized within 1 μ s accuracy
- » All-in-one cabling
- » Built-in laser safety control

BENEFITS OF MULTI-SENSOR SUPPORT

- » Ideal for scanning large or complex targets
- » Simple point-and-click network setup
- » Built-in layout alignment and stitching for maximum ease of use
- » Maintains high resolution across wide FOV



Master 810. Supports up to 8 sensors.



Master 2410. Supports up to 24 sensors.

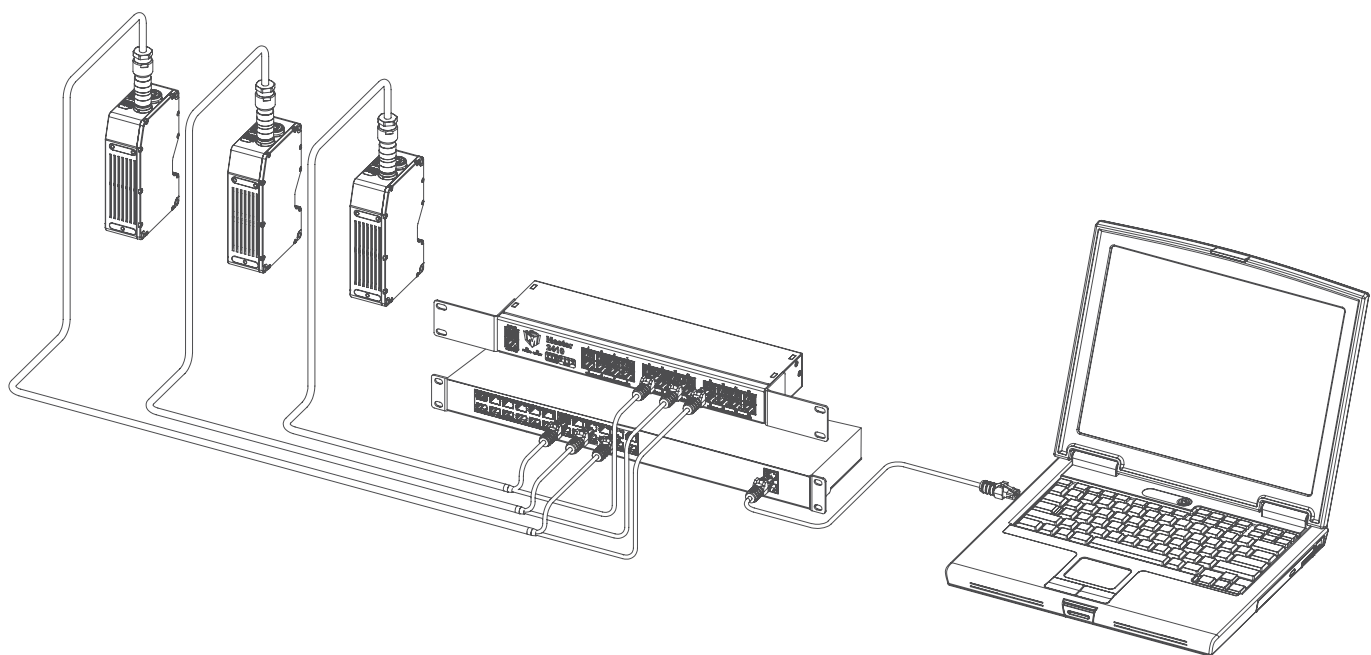

It's Better to Be Smart.

contact@lmi3d.com | lmi3d.com

AMERICAS

LMI Technologies Inc.
Burnaby, BC, Canada

EMEAR

LMI Technologies GmbH
Teltow/Berlin, Germany

ASIA PACIFIC

LMI (Shanghai) Trading Co., Ltd.
Shanghai, China



LMI Technologies has offices worldwide. All contact information is listed at lmi3d.com/contact