



Robotiq Force Torque Sensor FT 150/300 Instruction Manual



© ROBOTIQ INC. 2016

Get the latest version of the manual at support.robotiq.com

Table of Contents

Revisions	3
1. General Presentation	3
2. Safety	7
2.1 Warning	9
2.2 Intended use	10
3. Installation	11
3.1 Scope of delivery	11
3.2 Environmental and operating conditions	12
3.3 Mechanical connections	13
3.4 Power supply specifications	15
3.5 Wiring	16
3.5.1 Wiring with USB to RS485 converter	17
3.5.2 Wiring with RS232 to RS485 converter	18
3.6 Calibration procedure	19
3.6.1 Calibration procedure with Universal Robots	19
3.6.2 Calibration procedure for the Visual Demo Software (PC)	23
3.7 Status LED	24
3.8 Installation for Universal Robots	26
3.8.1 URCaps Package	27
3.8.2 UR Package without URCaps	32
4. Software	34
4.1 Control with Universal Robots	35
4.1.1 ActiveDrive Toolbar	36
4.1.2 Path Recording	40
4.1.3 Driver Package to access Force Torque Signal	44
4.2 Development package	46
4.2.1 Linux	47
4.2.2 Windows	49
4.3 ROS	51
4.4 Visual Demo Software	51
4.5 Serial communication	53
5. Specifications	54
5.1 Technical dimensions	55
5.1.1 Robot side bolt pattern	57
5.1.2 Tool side bolt pattern	58
5.2 Mechanical specifications	59
5.2.1 Moment of inertia and center of mass	61
5.2.2 Overload Capacity	62
5.3 Signal specifications	62
5.4 Electrical ratings	64
5.5 Couplings	65
5.5.1 Blank coupling	66
6. Maintenance	68
7. Spare Parts, Kits and Accessories	68
8. Troubleshooting	69
9. Warranty	72
10. Contact	73
A. Harmonized standards, declarations and certificates	74
A1. Translation of original EC declaration of incorporation	75
A2. Applied standards	75

Revisions

Robotiq may modify this product without notice, when necessary, due to product improvements, modifications or changes in specifications. If such modification is made, the manual will also be revised, see revision information.

See the latest version of this manual online at: <http://support.robotiq.com/>.

Revision 2016/11/18

Updated FT-150 signal specifications (section 5.3)

Updated installation for Universal Robots (section 3.8 and sub sections)

Updated Control with Universal Robots (section 4.1 and sub sections)

Revision 2016/04/26

Update for ActiveDrive toolbar, added calibration instructions

Revision 2016/01/18

Update for FT-300

Revision 2014/09/08

Official release

Copyright

© 2016 Robotiq Inc. All rights reserved.

This manual, and the product it describes, are protected by the Copyright Act of Canada, by laws of other countries, and by international treaties, and therefore may not be reproduced in whole or in part, whether for sale or not, without prior written consent from Robotiq. Under copyright law, copying includes translation into another language or format.

Information provided by Robotiq in this document is believed to be accurate and reliable. However, no responsibility is assumed by Robotiq for its use. There may be some differences between the manual and the product if the product has been modified after the edition date.

The information contained in this document is subject to change without notice.

1. General Presentation

Terminology :

The terms "Sensor", "Robotiq Sensor", "Force Sensor", "Torque Sensor", "FT Sensor" used in the following manual refer to the **Robotiq Force Torque Sensor FT 150** and **Robotiq Force Torque Sensor FT 300** unless specified. The Robotiq FT sensor comes in two version, FT 150 and FT 300. Both version are physically different but the concept of utilization and the software provided by Robotiq is the same for both products. The following manual instructions apply to both versions unless explicitly stated otherwise. The Robotiq FT sensor is a robotic peripheral designed for force and torque data acquisition. The FT Sensor is meant to have an end-of-arm tool mounted on it, so that it can sense force and torque applied on the tool. The Sensor is compatible with various tools and provides feedback that can be used for: hand guiding a robot, force control processes, assembly tasks, product testing, etc.

Note

The following manual uses the metric system, unless specified, **all dimensions are in millimeters**.

Note

The following section presents the key features of the Sensor and should not be considered as being related to Sensor operation, each feature is detailed in the appropriate section of the manual. Safety guidelines must be read and understood before any operation is attempted with the Sensor.

FT-150 vs FT-300 :

Although both versions of the FT Sensor share the same features and method of installation / integration, they are physically different, see Figure 1.

Difference :

Feature	FT-150	FT-300
Connectivity	M12 mounted connector	Pigtail cable (1 m) with M12 connector
Thru hole	Yes	No
Outside diameter	120 mm	75 mm
Inner diameter	45 mm	N/A
Thickness	37.5 mm	37.5 mm
Weight	650 g	300 g
Sensing range	±150 N	± 300 N
	± 15 N*m	± 30 N*m

Similitude :

Feature	FT-150	FT-300
Effective resolution	0.2 N	
	0.02 N*m	
Cross-talking	None	
External noise sensitivity	Immune	
Overload capacity	500%	
Input Voltage	24 V DC	
Maximum power consumption	2 W	

Communication interface	RS-485, USB
-------------------------	-------------

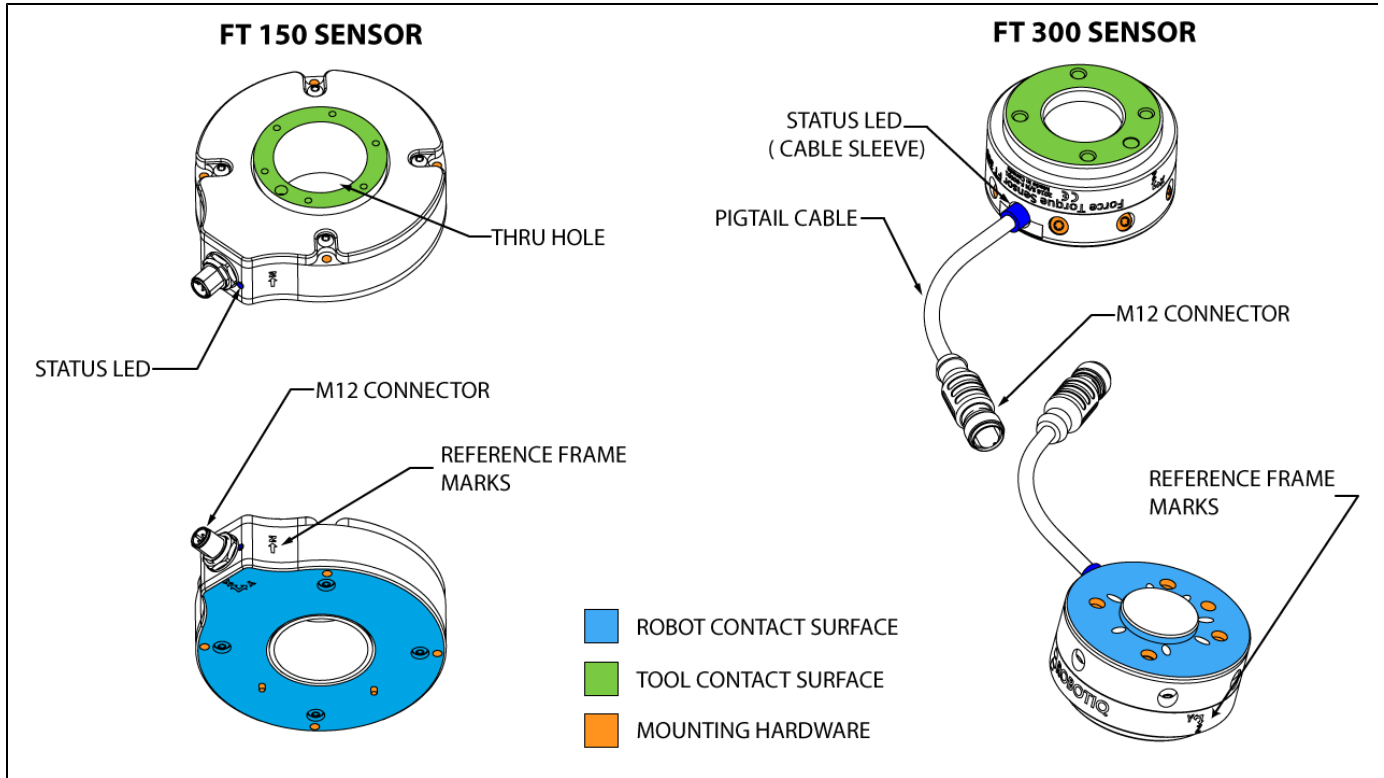

Figure 1.1 : General presentation of the Robotiq Force Torque Sensors with main features.

FT Sensor main features :

- The end-of-arm tool contact surface (in green) is the only point of contact allowed between the Sensor and the tool to ensure correct force and torque feedback.
- The robot contact surface (in blue) is the only contact point allowed between the Sensor and the robot for fastening the sensor to the robot. Note that the inside ring must **not** touch the robot.

Info

Details on the bolt pattern and indexing pin for the tool side and the robot side can be found in the specification section.

- The screw positioning for the coupling and the robot mountings are shown in orange. See the [Spare Parts section](#) for a list of available Couplings.
- M12 connector (pigtail or mounted) allows for both power and data transfer for the Sensor.
- Status LED provides visual information on the status of the Sensor, see [Section 3.6](#) for details.
- The thru hole is used in conjunction with hollow wristed robots to pass cables (only on the FT 150).

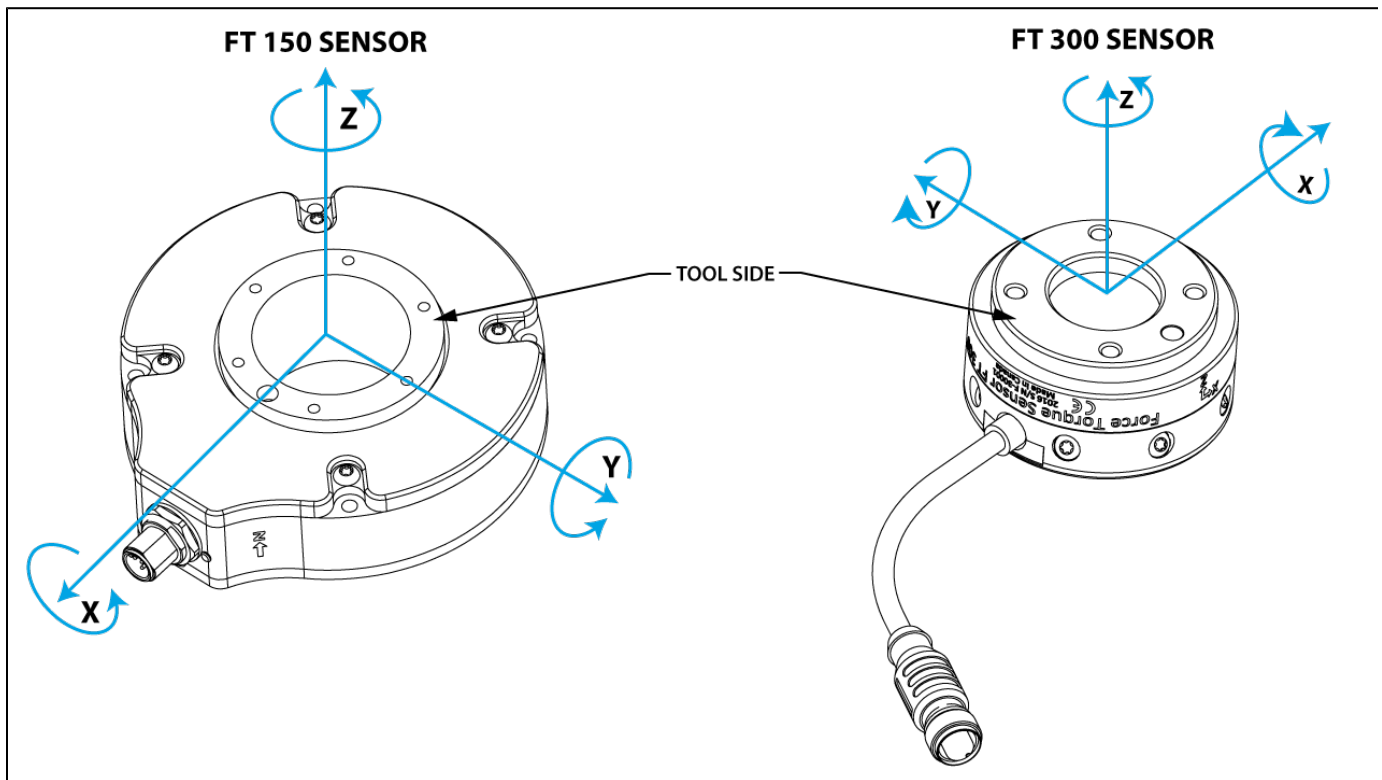

Figure 1.2 : FT Sensor force and torque diagrams.

Figure 1.2 represents the various force and torques that the FT Sensor can measure. Reference frame is centered on the Sensor as shown above and visual inscriptions are also represented on it.

- For both Sensors, the Z axis passes through the center of the thru hole with positive direction in the tool direction.
- For both Sensors, the X axis traces a symmetric line centered on the connector,
 - The FT 150 positive direction points towards the connector,
 - The FT-300 positive direction points the opposite way; away from the connector,
- For both Sensors, the Y axis uses the right hand thumb rule according to X-Z.

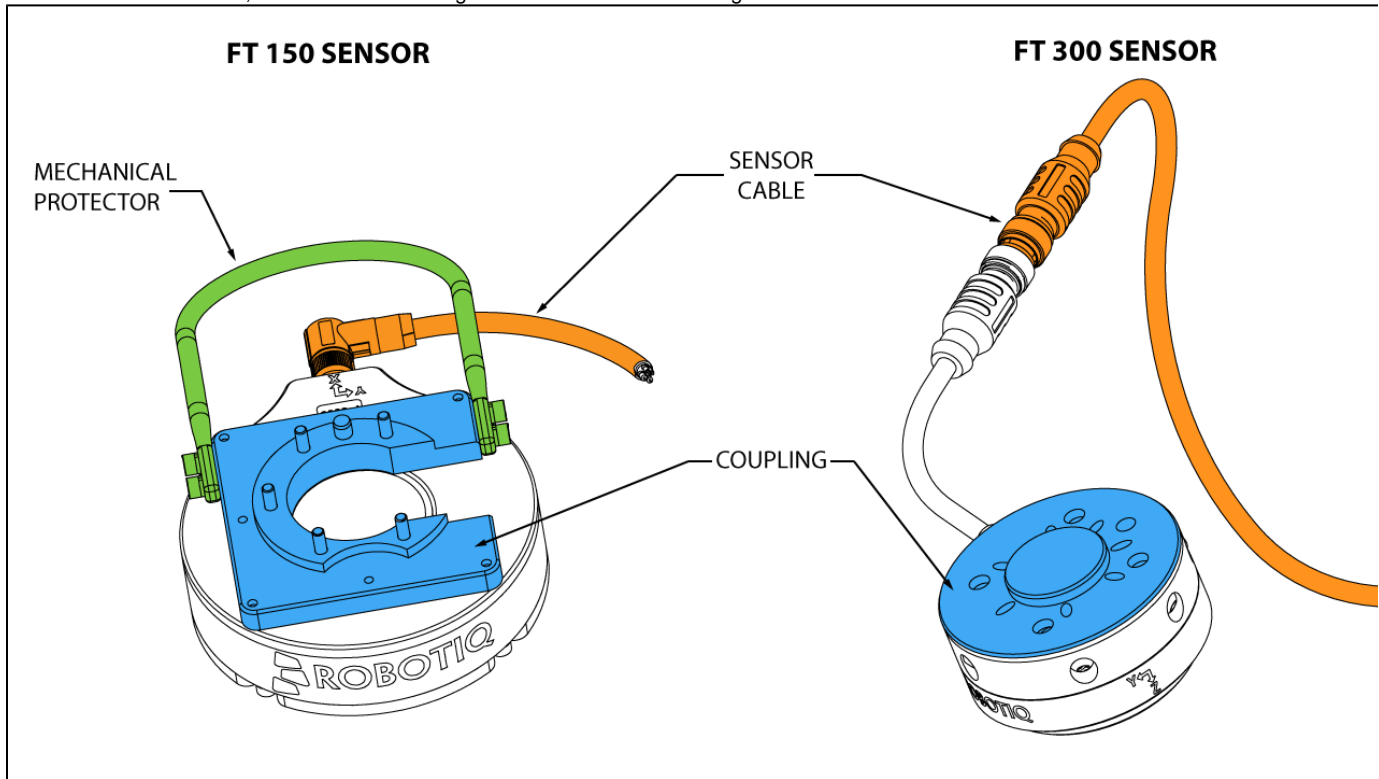

Figure 1.3 : FT Sensor options.

Figure 1.3 above represents various options available. They can be found in [Section 7. Spare Parts, Kits and Accessories](#).

- **Couplings** are meant to install the FT Sensor on various robot models, see available models.
- **Sensor Cable** is used for power and communications with the FT Sensor and is available in different lengths.
- **Mechanical Protector** is meant to protect the cable connector from collisions that can occur when operating the robot (especially useful when in teach mode) (**only for the FT 300**).
- **Tool Plate** is not shown, but might be required when certain end-of-arm tools are mounted on the FT Sensor.

Info

See [Section 3. Installation](#) for details on the installation of various options.

Various software packages are provided (identical for both version) and detailed in [Section 4](#). of this manual.

Tip

It is important to understand that the FT Sensor can be used either as a Modbus RTU slave or as a streaming device. When use as a slave unit you will send status requests (read function) to get the force & moment values, while when in data stream mode the Sensor will continuously stream data without responding to a master request, see [Section 4.4](#) for details.

2. Safety

Warning

The operator must have read and understood all of the instructions in the following manual before handling the Robotiq Force Torque Sensor.

The term "operator" refers to anyone responsible for any of the following operations on the FT 150 or FT 300 and associated robot or tools :

- Installation
- Control
- Maintenance
- Inspection
- Calibration
- Programming
- Decommissioning

This documentation explains the various components of the Force Torque Sensor, as well as general operations regarding the whole life-cycle of the product; from installation to operation and decommissioning.

The drawings and photos in this documentation are representative examples and differences may exist between them and the delivered product.

2.1 Warning

Note

Any use of the Sensor in noncompliance of these warnings is inappropriate and may cause injury or damage.

Warning

A Force Torque Sensor used in human-robot collaboration must not be considered a complete safety measure, additional dedicated safety device(s) must be considered. Sensor failure can occur and result in danger for workers or machinery if not properly secured. See local or international safety measure for human-robot collaboration.

Warning

- The Sensor needs to be properly secured before operating the robot.
- Do not install or operate a Sensor that is damaged or lacking parts.
- Never supply the Sensor with an alternative current.
- Make sure all cord sets are always secured at both ends, at the Sensor and at the robot.
- Always respect the recommended keying for electrical connections.
- Be sure no one is in the robot and/or Sensor path before initializing the robot's routine.
- Always respect the Sensor payload.
- All local safety measures and/or laws on robot operation must be applied to the Sensor.

Any use of the Sensor in noncompliance with these warnings is inappropriate and may cause injury or damage.

2.2 Intended use

The Sensor is designed for data acquisition (force and torque sensing) for an end-of-arm tool on a robot.

The product is intended for installation on a robot or other automated machinery or equipment.

Note

Always comply with local and/or national laws, regulations and directives on automation safety and general machine safety.

The unit may be used only within the range of its technical specifications. Any other use of the product is deemed improper and unintended use. Robotiq will not be liable for any damages resulting from any improper or unintended use.

3. Installation

Warning

Be sure to read and understand the [safety instructions](#) related to the Robotiq Force Torque Sensor prior to installation.

3.1 Scope of delivery

Standard delivery for an FT Sensor kit :

FTS-150-KIT-001	FTS-300-KIT-001
Robotiq Force Torque Sensor FT 150 unit	Robotiq Force Torque Sensor FT 300 unit
N/A	1 m pigtail cable
10 m Robotiq Device Cable (CBL-PWR-2054-10)	10 m Robotiq Device Cable (CBL-PWR-2054-10)
USB Signal Converter (ACC-ADT-USB-RS485)	USB Signal Converter (ACC-ADT-USB-RS485)

Options :

- Couplings

Note

Coupling is optional for the FT 150, but mandatory for the FT 300.

- Adapter plates
- Tool plates
- Mechanical Protector

Info

Only available with the FT 150.

- Different cable lengths

Note

The following are not included in delivery unless specified in the purchase:

- Options such as couplings and adapters for mounting on divers industrial robots.
- Hardware required for options; accessories or fixtures for the FT Sensor unless specified.
- Power supply units, power supply wiring or fuses.

See [Spare Parts, Kits and Accessories](#) section for a list of available parts.

3.2 Environmental and operating conditions

The FT Sensor is designed for industrial applications. Always respect the following specified storage, transport and operating environmental conditions:

	FT 150 / FT 300
Minimum storage/transit temperature	-25°C
Maximum storage/transit temperature	70°C
Minimum operating temperature	15°C
Maximum operating temperature	35°C
Humidity (non-condensing)	20-80% RH
Vibration (storage / transit)	5G
Vibration (operating)	2G
Others	<ul style="list-style-type: none">• Free from dust, soot or water• Free from corrosive liquids or gases• Free from explosive liquids or gases• Free from powerful electromagnetic interference

3.3 Mechanical connections

You must use a coupling to attach the Sensor to a robot. Be sure to use the coupling related to your robot model. Our couplings are listed according to ISO 9409-1 and this covers most bolt patterns. If there is no coupling for your robot, you can modify a blank coupling or Robotiq can create a custom version for you. Some couplings may require an additional adapter plate. To create your own coupling or adapter plate you can refer to the [Technical Dimensions section](#). To see available couplings and adapter plates and for details, see the [Spare Parts, Kits and Accessories section](#).

Note

The FT 300 coupling is mandatory, you can customize yours from a blank provided by Robotiq.

Here are the steps to follow for the installation of the Sensor (see Figure 3.3.1 and 3.3.2). Note that all screws must be locked in place using medium strength threadlocker, such as *Loctite 248* or a similar product.

1. Align the indexing dowel pin between the coupling and the robot (usually press fitted to the robot).
2. Screw the coupling to the robot with the robot mounting screws (with lock washers if provided) and threadlocker.
3. Align the Sensor indexing dowel pins (prefixed to the Sensor) to the coupling.
4. Screw the Sensor to the coupling using the coupling mounting screws (with lock washers if provided) and threadlocker.

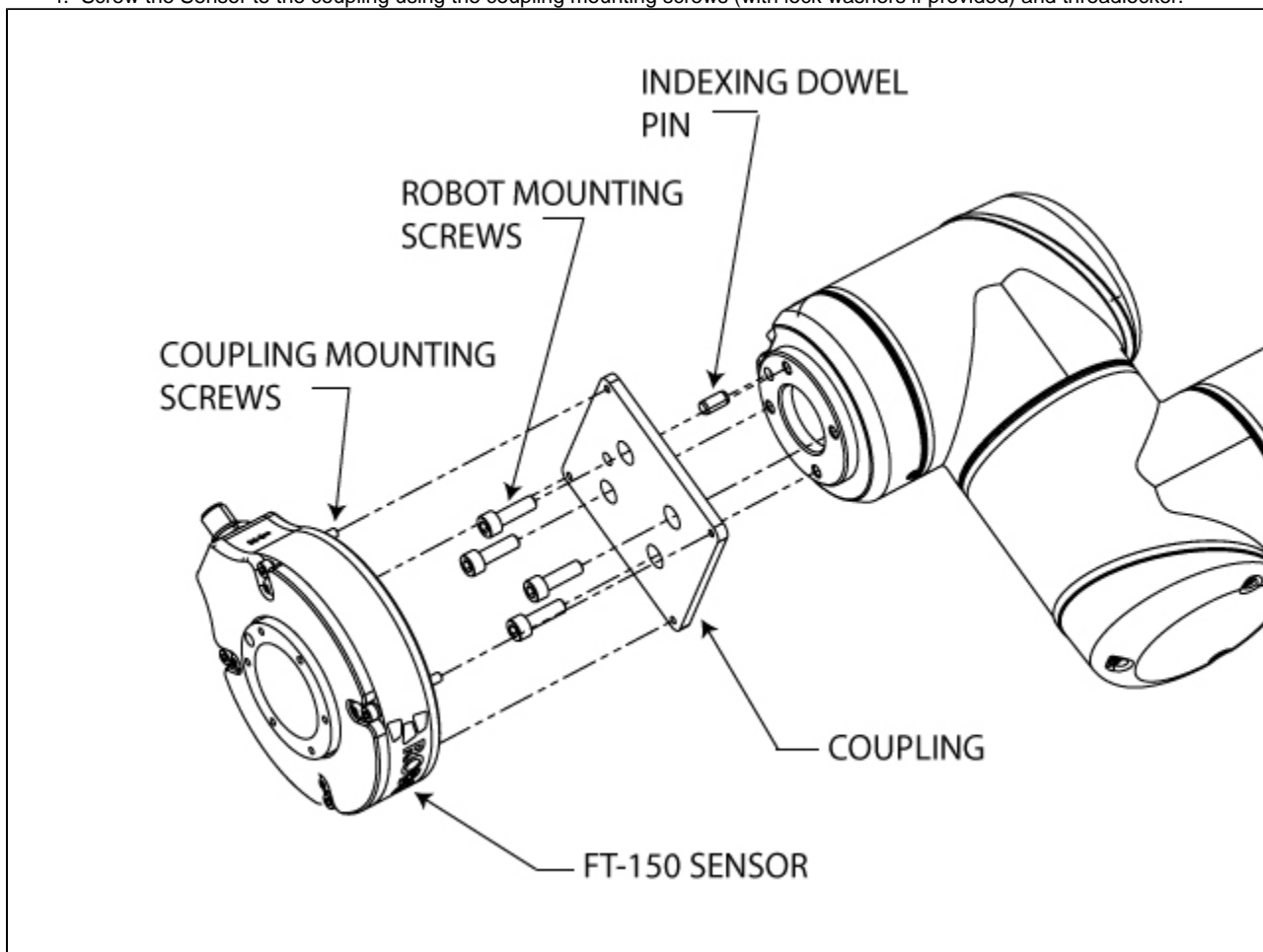

Figure 3.3.1 : Attaching the FT 150 sensor to a robot arm with a coupling

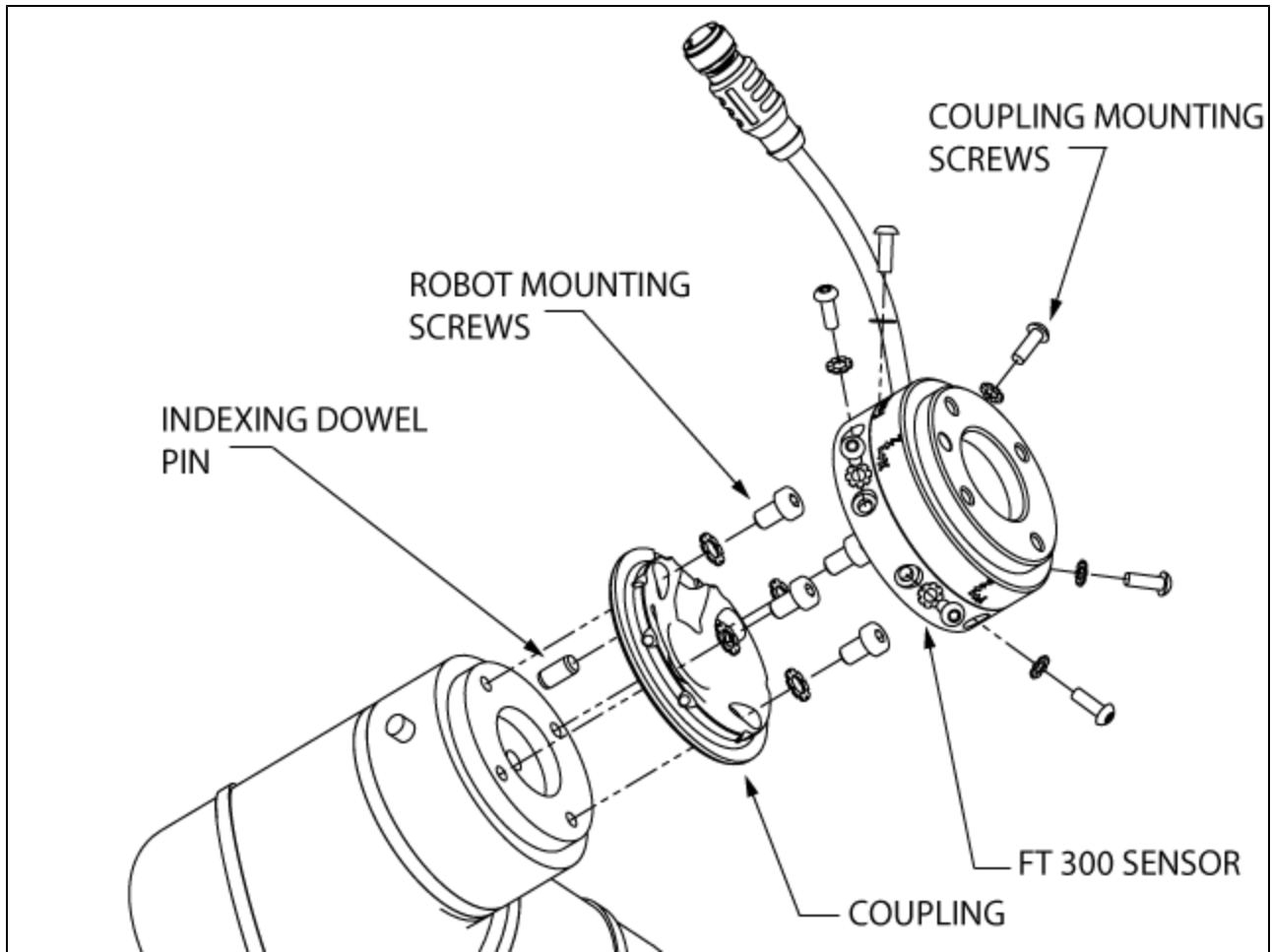

Figure 3.3.2 : Attaching the FT 300 sensor to a robot arm using the mandatory coupling.

3.4 Power supply specifications

The Sensor needs to be supplied by a DC voltage source. This power supply is not included with the Sensor.

POWER SUPPLY SPECIFICATIONS	FT-150	FT-300
Output voltage	6 to 24 V DC	5 to 24 V DC
Max power consumption	2 W	2 W
Overcurrent	1 A Fuse (Phoenix #0916604 (UT6-TMC M 1A))	
Overvoltage protection	<div style="border: 1px solid red; padding: 5px;"> <p>Warning Maximum output voltage tolerance is 10%, exceeding this limit, 26.4 V DC could damage the Sensor.</p> </div>	

Info

Robotiq recommends the use of the following power supply :

TDK-Lambda DPP Series, *15W Single Output DIN Rail Mount Power Supply*, **DPP15-24**

3.5 Wiring

Power and communications are established with the FT Sensor via a single device cable. The pinout is the same on both versions of the FT Sensor although the FT 150 has a mounted connector, while the FT 300 has a pigtail cable.

Both the FT 150 and FT 300 cables maintain the same wiring standard, but the FT 150 cable has a 90 degree angled connector, while the FT 300 pigtail cable has a straight connector which includes the LED power light. Figure 3.5.1 represents the FT Sensor receptacle (Sensor side) and connector (cable side) with associated pinout. The M12 - 5 pin A-coded connector is used in accordance with IEC 61076-2-101. Both versions of the Sensor share the same M12 5 pins / male pinout.

Warning

Use proper cabling management. Be sure to have enough forgiveness in the cabling to allow movement of the Gripper along all axes without pulling out the connectors. Always protect the controller side of the cable connection with a strain relief cable clamp.

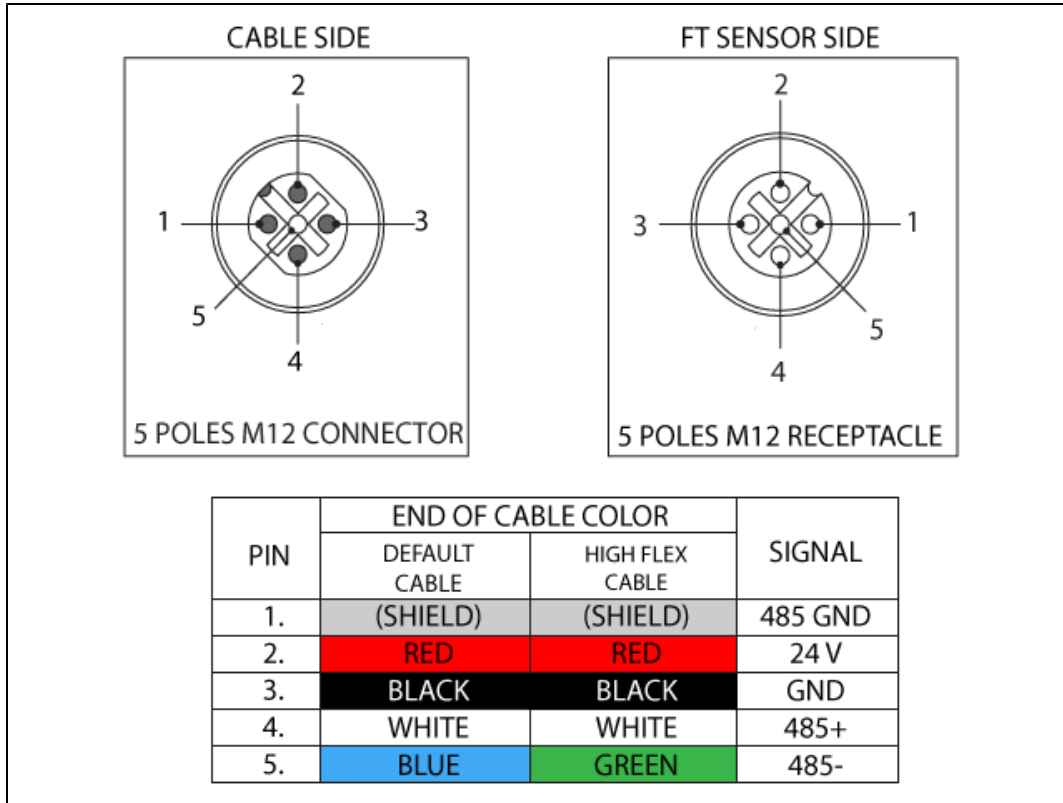

Figure 3.5.1 : Pinout of the Robotiq Force Torque Sensor FT 150/300 and color code for the respective cable type.

Info

Power pins 2 & 3 are connected to the specified power supply.

Info

RS-485 signal pins 1, 4 & 5 are connected directly, to a RS-485 / USB converter or to a RS-485 / RS-232 converter.

3.5.1 Wiring with USB to RS485 converter

When using a RS485 to USB converter (see [Spart Parts, Kits and Accessories section](#)), the wiring must respect Figure 3.5.1.1 and the following directions. GND / 0V is wired to Sensor pin #1 as stated in Section 3.5.

The converter will provide you with a standard USB 2.0 male A connector.

Warning

Power is not delivered via the USB, **do not plug 24V into the USB.**

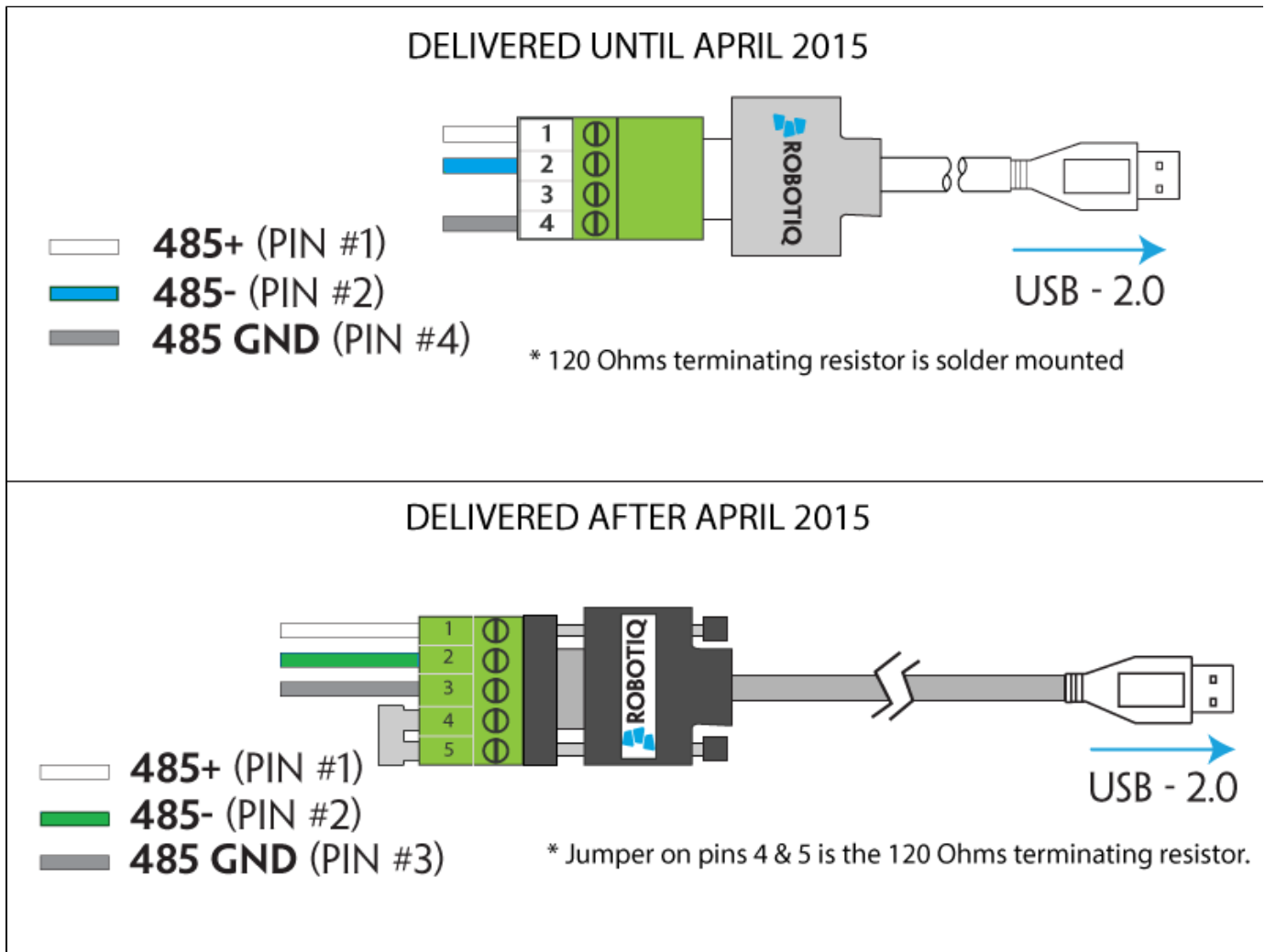

Figure 3.5.1.1 : Wiring diagram for the different RS485 to USB converters delivered before & after April 2015.

3.5.2 Wiring with RS232 to RS485 converter

When using a RS232 to RS485 converter (see [Spart Parts, Kits and Accessories](#) section), the wiring must respect Figure 3.5.2.1.

Warning

Do not wire converter pin #3 (5V) on the RS485.

The 24V power supply is **NOT** supplied via the converter.

The converted side will provide you with a standard DB - 9 female connector with signaling as shown in Figure 3.5.2.1.

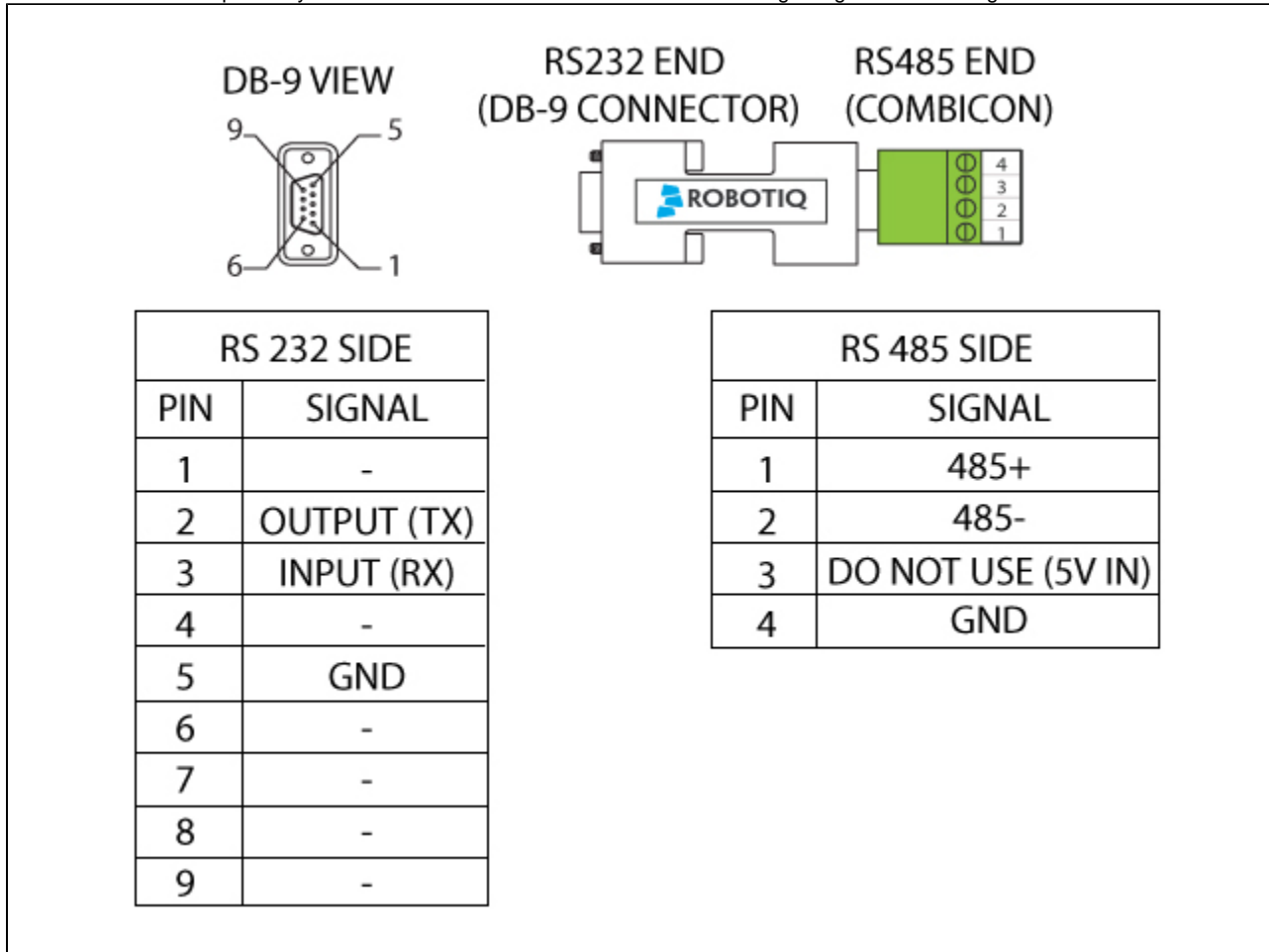

Figure 3.5.2.1 : Wiring diagram for RS232 to RS485 converter.

3.6 Calibration procedure

Why do I need to calibrate the installation offset of my FT-150 / FT-300 ?

The sensor outputs the force and moment data according to a reference, i.e. a zero value. In order to compensate for any deviation of this reference, Robotiq provides a new feature which allows the sensor to automatically compute and compensate the installation offset, the weight of the tool and its center of mass.

Warning

The sensor must be re-calibrated after each uninstall / install on the robot. Mounting screws will induce internal stress that needs to be compensated for. Not doing so will significantly affect the sensor signal.

How does it work?

The procedure requires moving the robot in three configurations for which each orientation of the tool is different. Using an internal accelerometer, the sensor is then able to associate the measurements corresponding to the tool alone for each orientation. After the procedure is completed, the sensor will output the force and moment measured without the effect of the weight of the tool and the installation offset.

3.6.1 Calibration procedure with Universal Robots

Info

You need the Universal Robots software package installed first, see [Section 3.8](#) for the package download and installation.

To calibrate your FT Sensor :

1. Inside Polyscope, load the program, `calib_tool_.urp`, located in the folder called: Sensor (for a CB2 robot, use program `calib_tool_CB2.urp`).

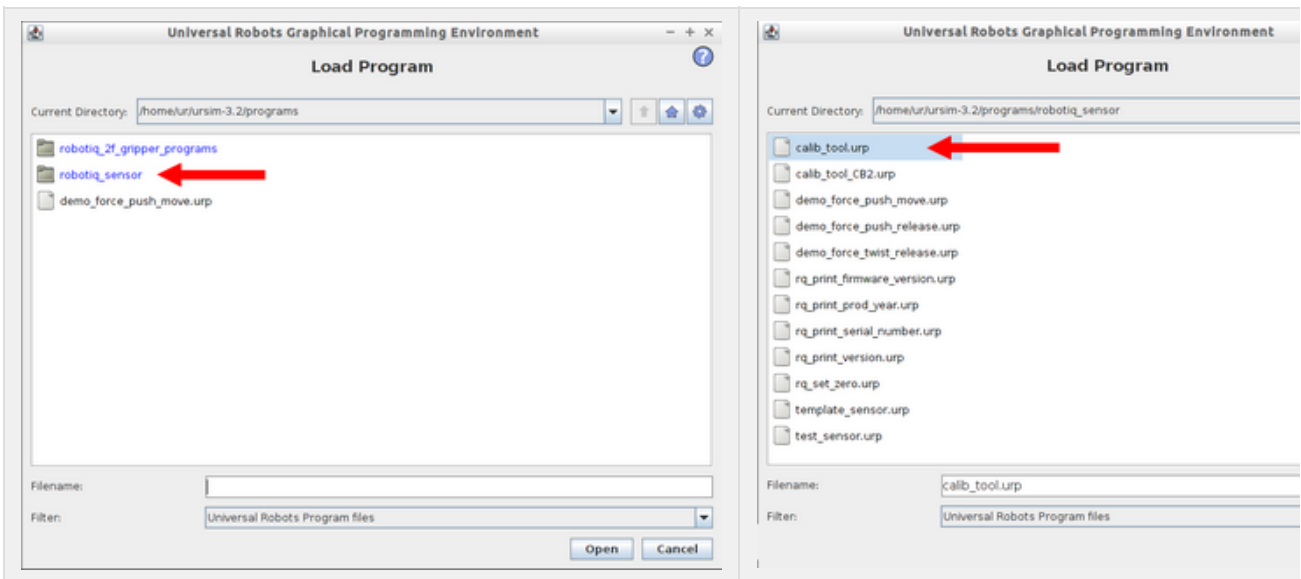

2. Run the program. Follow the instructions on the pop-ups. The displayed instructions explain how to move the robot through the three different poses. In each case, make sure that no external force is applied on the tool.

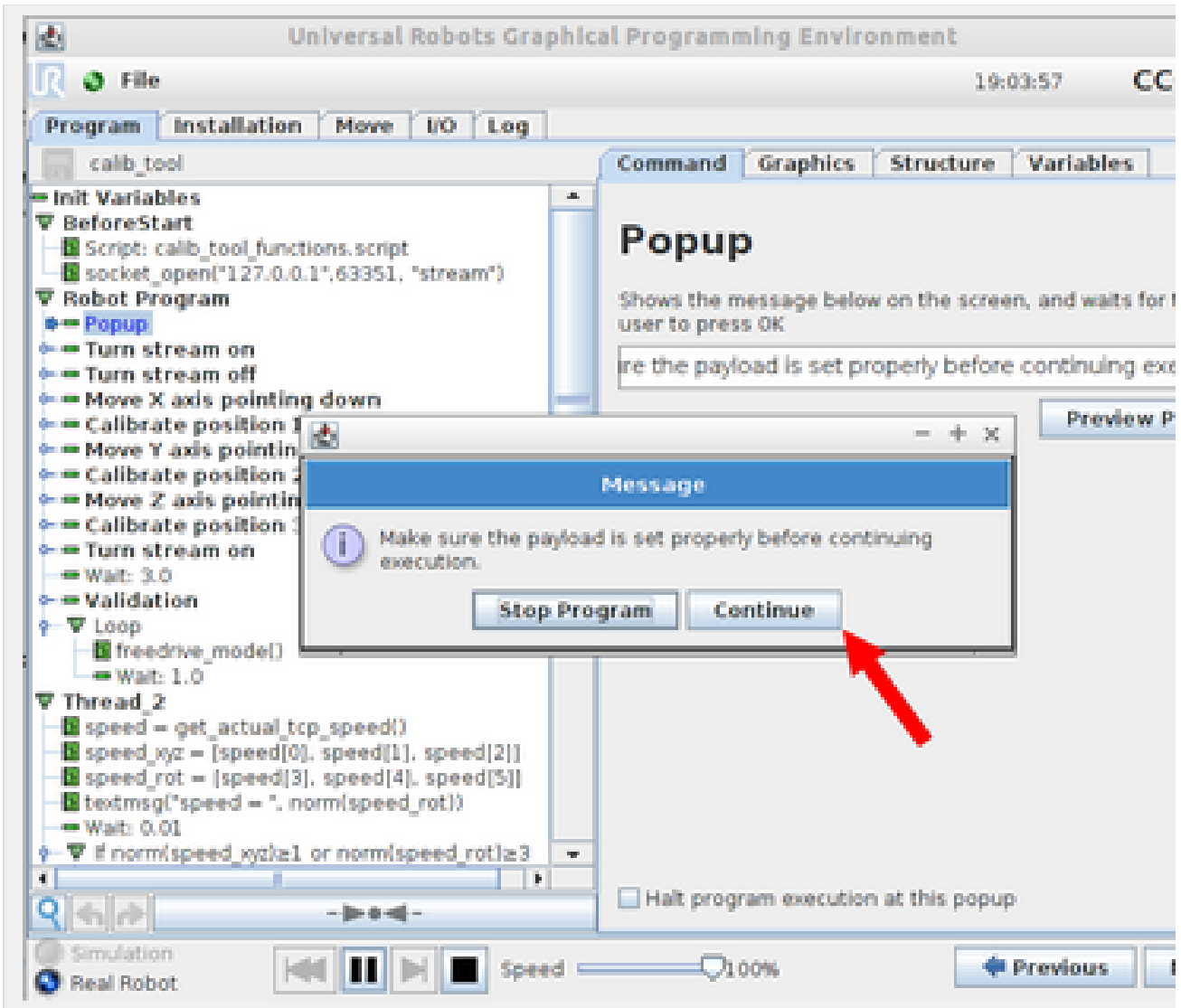

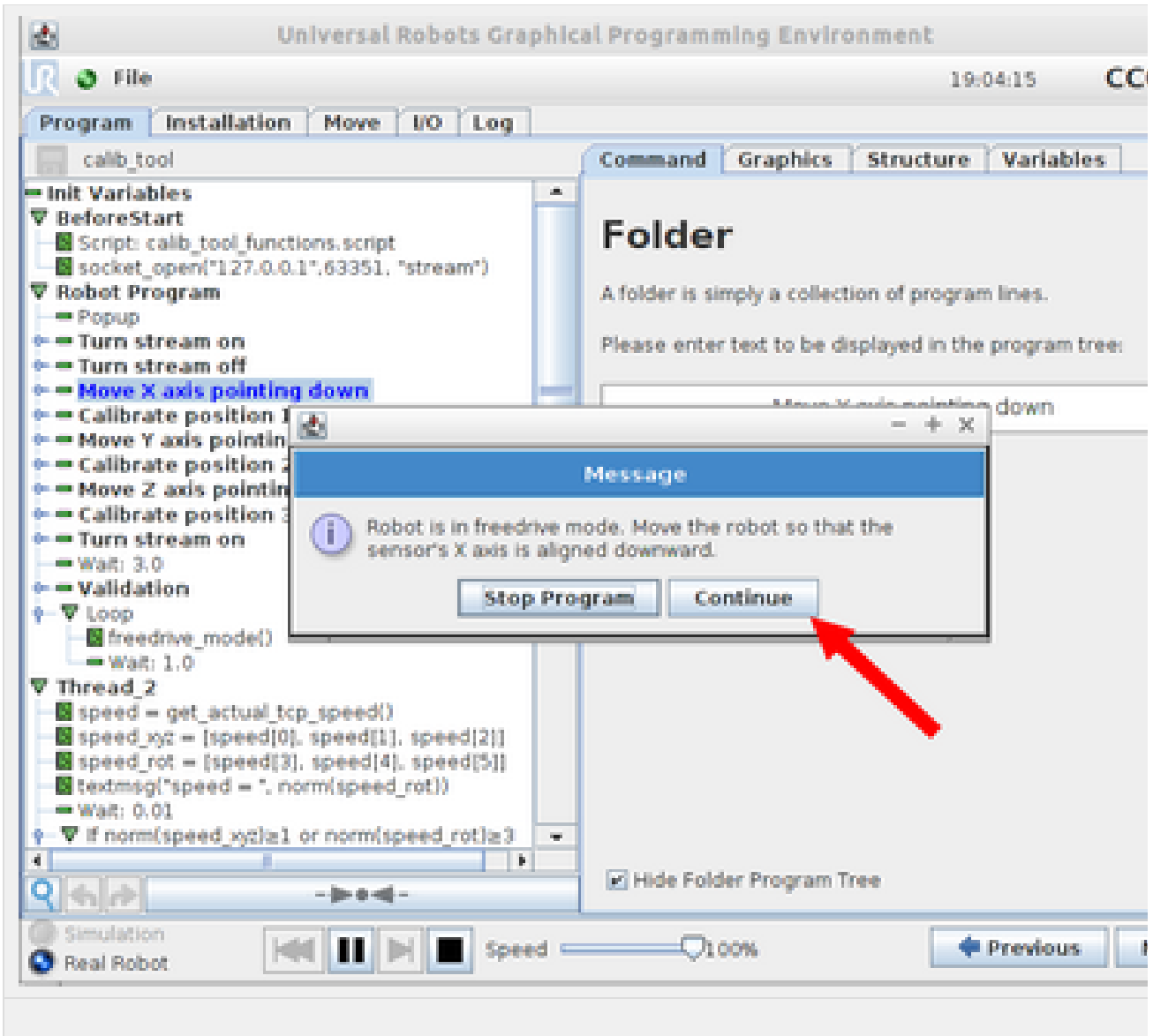

3. You can now monitor the forces in the Variables tab.

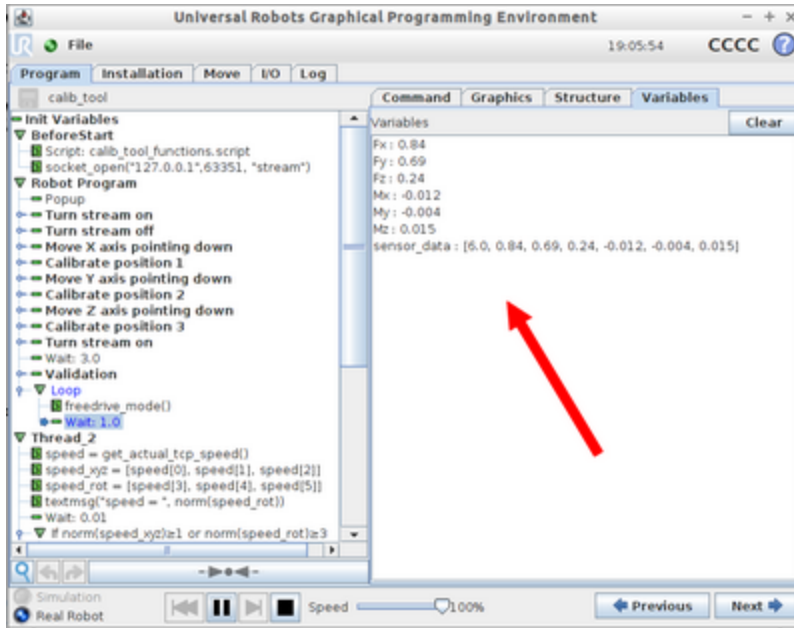

3.6.2 Calibration procedure for the Visual Demo Software (PC)

Info

You need the Visual Demo Software installed first, see [Section 4.4](#) for download and installation.

To calibrate your FT Sensor :

1. Go to the "Tool Calibration" tab and follow the instructions.

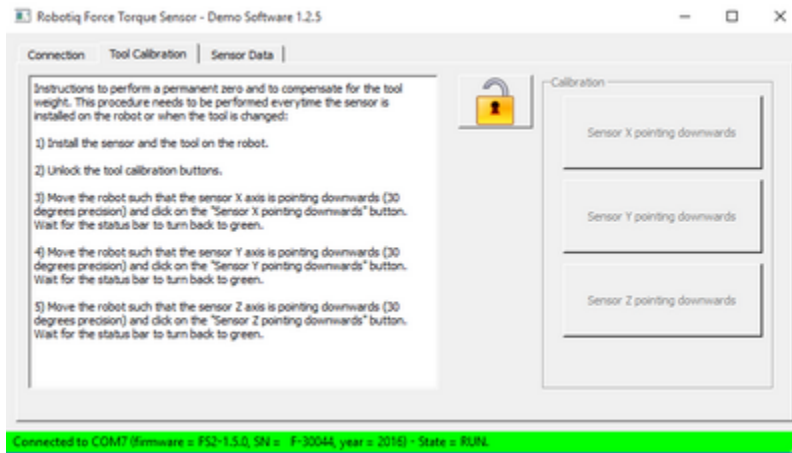

2. Once completed, go to the "Sensor Data" tab.

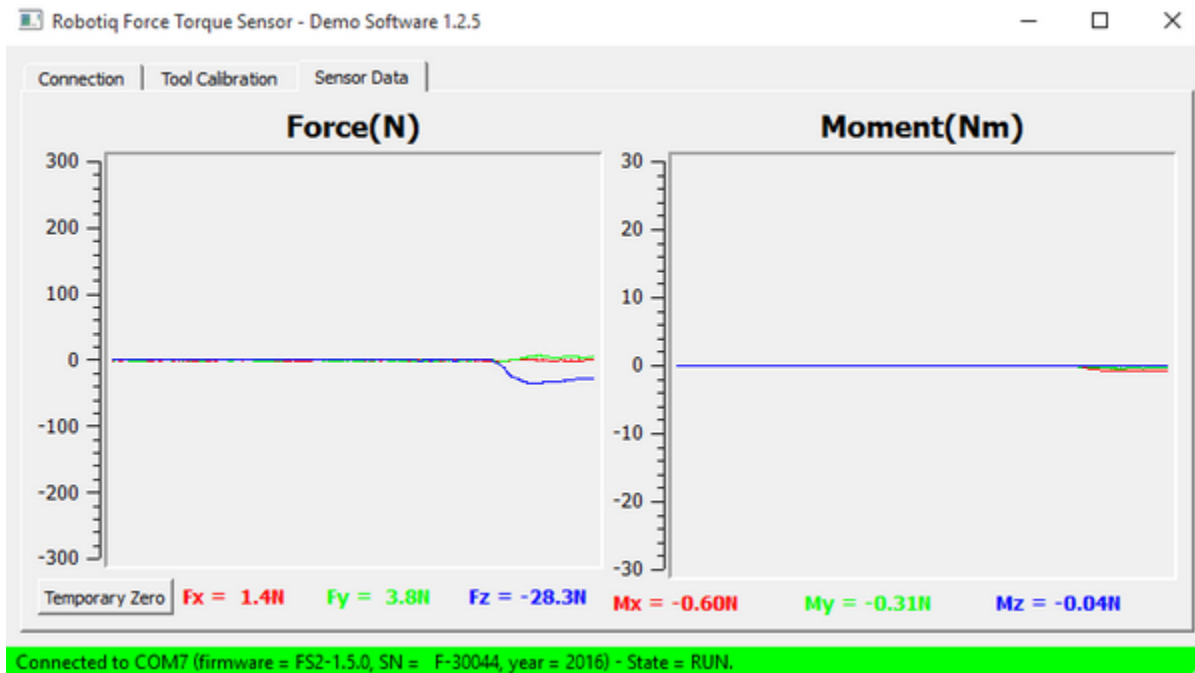

3.7 Status LED

A single status LED provides information on both Sensors, detailed information can be found in the tables below, while a representation of both Sensor status LEDs is shown in Figure 3.6.1.

On the FT 150 Sensor, the LED is located on the Sensor, next to the cable connector :

COLOR	LED STATE	INFORMATION
-	off	No power
Blue / red	on	FT 150 Sensor is booting
Blue	on	FT 150 Sensor is functional

On the FT 300 Sensor, the cable sleeve is the LED conductor :

COLOR	LED STATE	INFORMATION
-	off	No power
Blue / red	on	FT 300 Sensor is booting
Red	on	FT 300 is functional, no communication detected
Red	blinking	FT 300 Sensor fault detected
Blue	on	FT 300 Sensor is functional, communication established

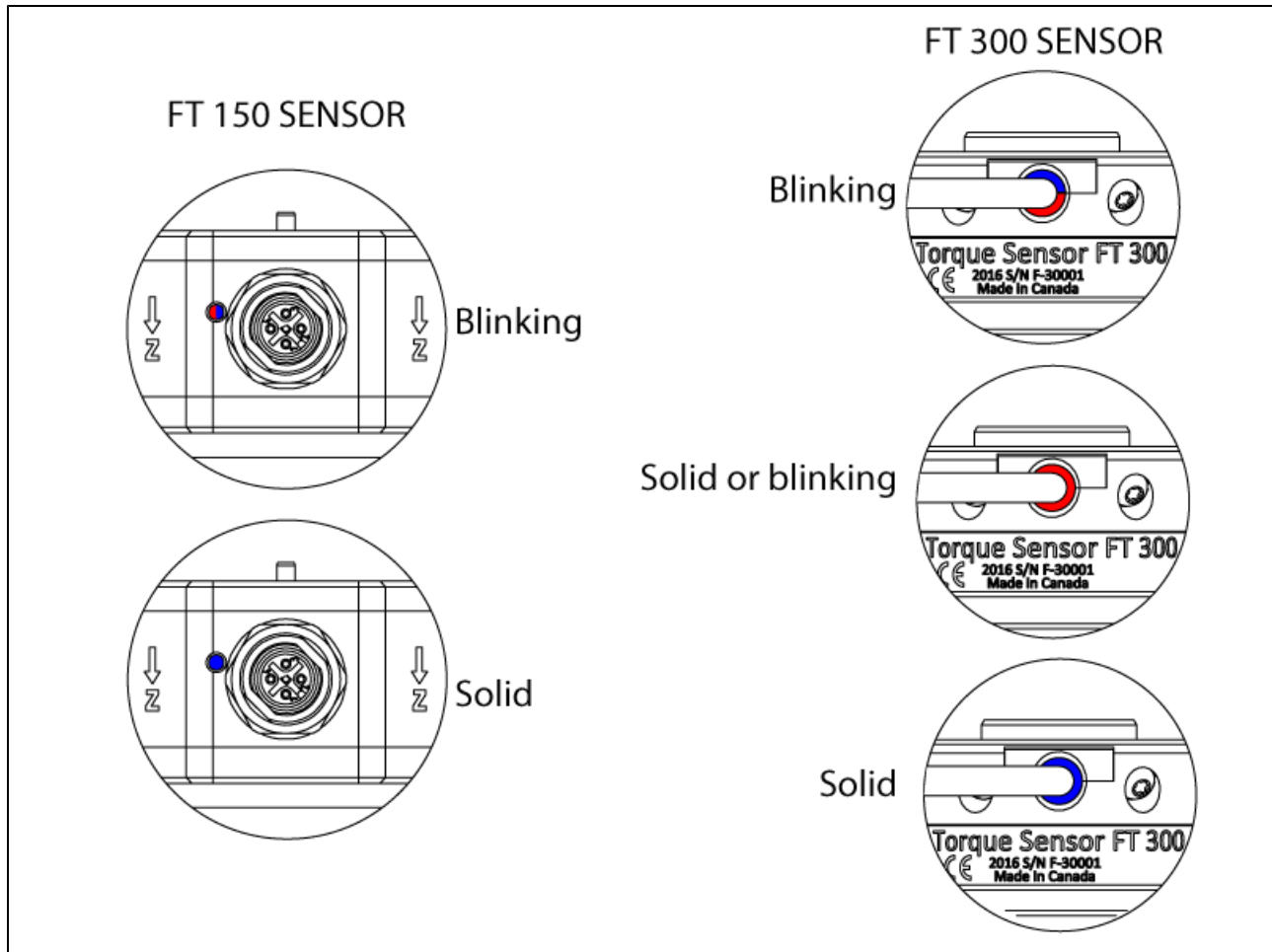

Figure 3.6.1 : FT Sensor status LED.

3.8 Installation for Universal Robots

The table below shows which Robotiq software to use with your version of Universal Robots' controller. If you are using a CB3 or CB3.1 controller, it is recommended to use the Force Torque Sensor URCaps Package.

Robotiq software	Universal Robots' controller version			
	CB1	CB2	CB3	CB3.1
Driver Package	Incompatible	Compatible	Compatible	Compatible
ActiveDrive Toolbar (Driver package must be installed)	Incompatible	Incompatible	Compatible	Compatible
Force Torque Sensor URCaps Package (includes driver package, ActiveDrive toolbar and Path node)	Incompatible	Incompatible	Compatible	Compatible

Refer to the appropriate section depending on your controller version:

- Section 3.8.1 covers the installation of the Force Torque Sensor URCaps Package.
- Section 3.8.2 goes through the software installation procedures when not using URCaps.

PolyScope Version

The robot's PolyScope version must be 3.3 and higher in order to install the URCap.

Prior to any software installation, connect the white, blue and bare wires to the Robotiq RS-485 signal converter (ACC-ADT-RS485-USB) as shown in Figure 3.8.1. Also connect the red (24V) and black (0V) wires in the controller according to Figure 3.8.1.

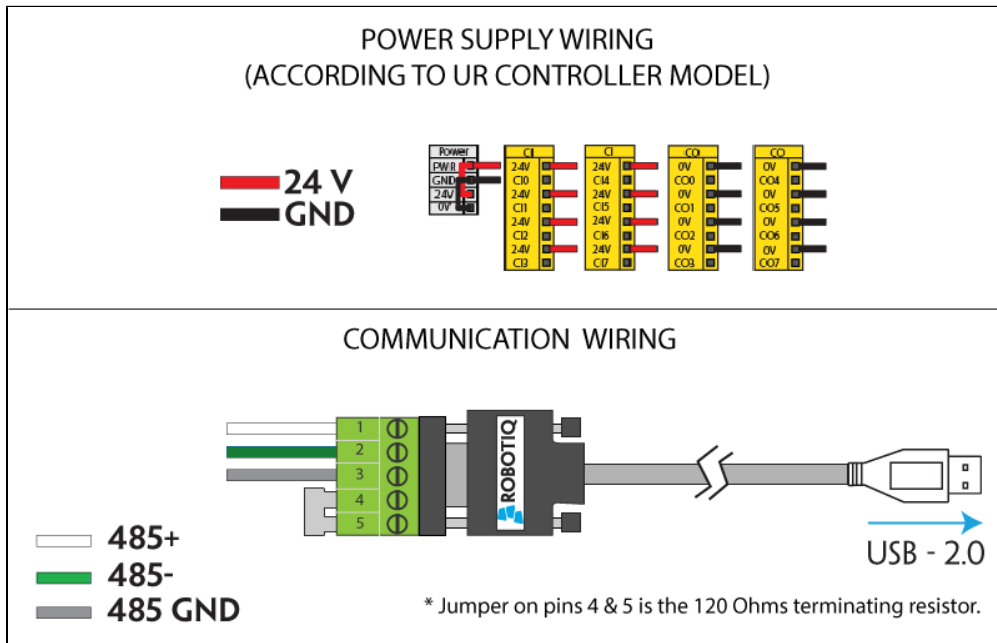

Figure 3.8.1 : Force Torque Sensor wiring to Universal Robots' controller.

Center of mass

Prior to use over *Universal Robots*, adjust the payload and the center of gravity from the Installation tab (refer to Section 5.2.1).

3.8.1 URCaps Package

PolyScope Version

The robot's PolyScope version must be 3.3 and higher in order to install the URCap.

Installation

Follow this procedure to install the Force Torque Sensor URCaps Package :

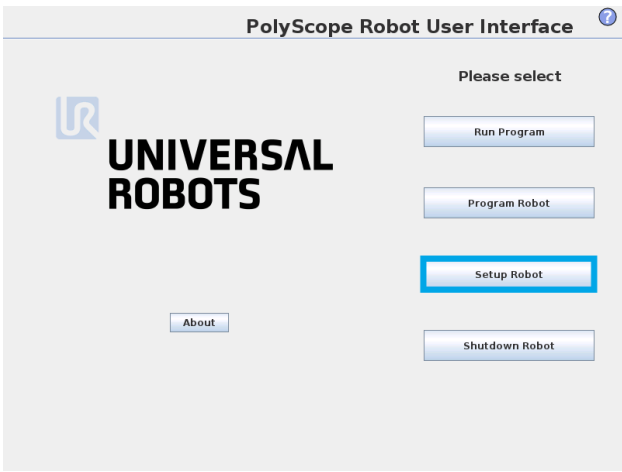
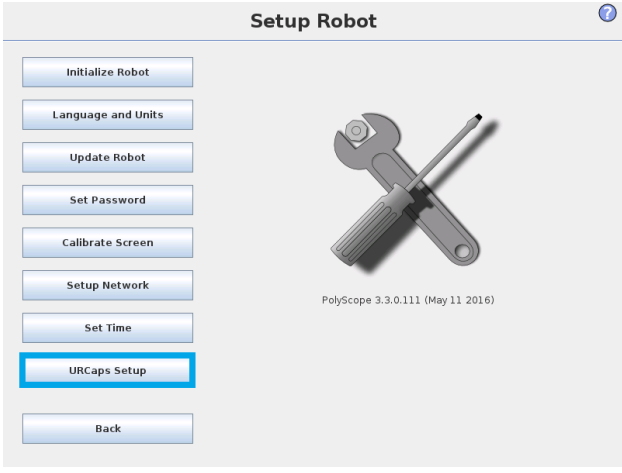
- Make sure that your Polyscope version is up-to-date and that your Universal Robots controller is compatible with the Force Torque Sensor URCaps package. Refer to Section 4.1 for the UR controller compatibility.
- Go to support.robotiq.com and click on the Force Torque Sensor product page.
- Download the **Robotiq_Force_Torque_Sensor-X.X.X.urcap** file on a blank USB stick.
- Insert the USB stick in the UR teach pendant or controller.
- Go in Setup Robot.
- Tap URCaps Setup.

In Polyscope, go in the Home page and tap the About button. A window containing the Universal Robots software version will pop up.

	<ul style="list-style-type: none"> • Tap the plus button (+) to add the Sensor's URCaps package. • Open Robotiq_Force_Torque_Sensor-X.X.X.urcap.
	<ul style="list-style-type: none"> • Restart Polyscope to complete the URCaps installation. By doing so, you accept the License Agreement that is detailed in the URCap Information text box (see below for the License Agreement).
	<ul style="list-style-type: none"> • When Polyscope reopens, the ActiveDrive toolbar will appear on the screen.

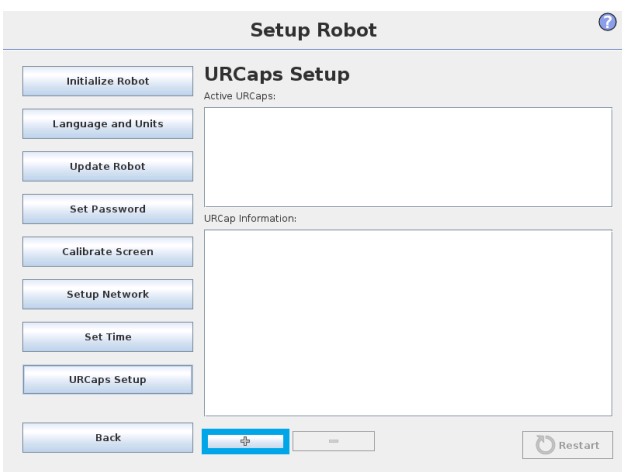
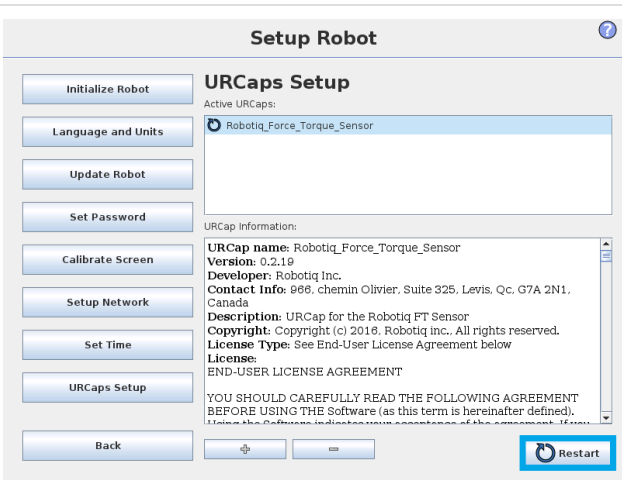
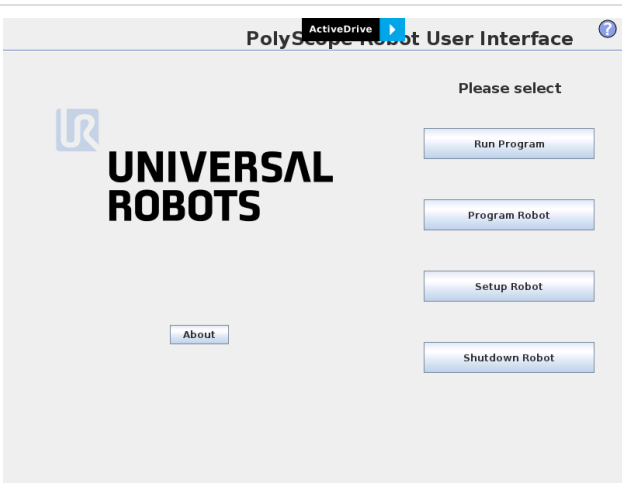
If the Force Torque Sensor is mounted on the robot for the first time, calibration must be performed. Refer to [Section 3.6.1](#) for the calibration procedure.

The sensor must be recalibrated after each uninstall / install on the robot. Mounting screws will induce internal stress that needs to be compensated for. Not doing so will significantly affect the sensor signal.

Uninstalling the URCaps Package

If you wish to uninstall the Force Torque Sensor URCaps, follow this procedure:

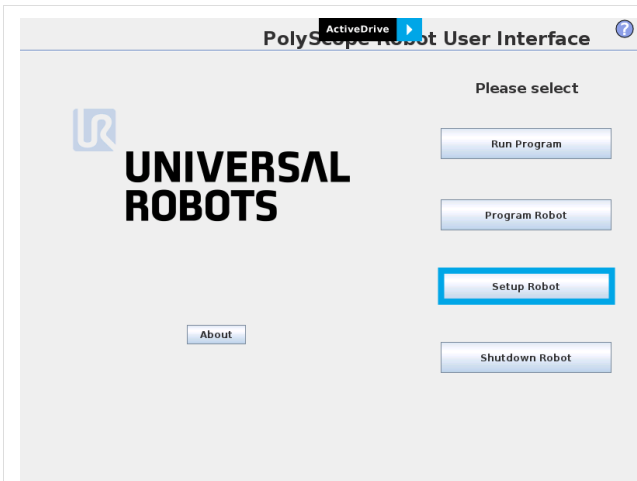

- Go in Setup Robot.

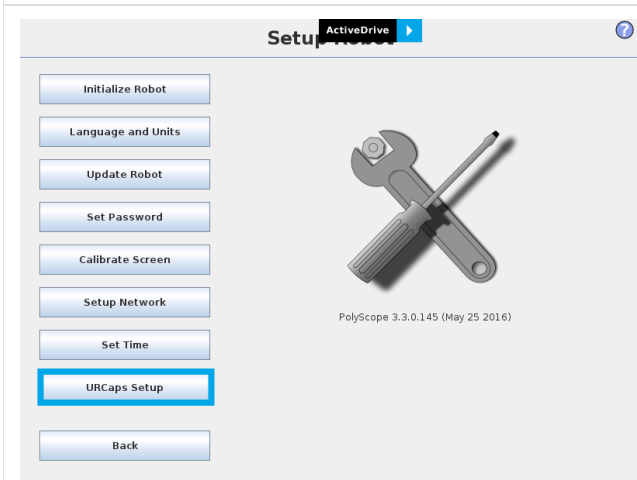

- Tap URCaps Setup.

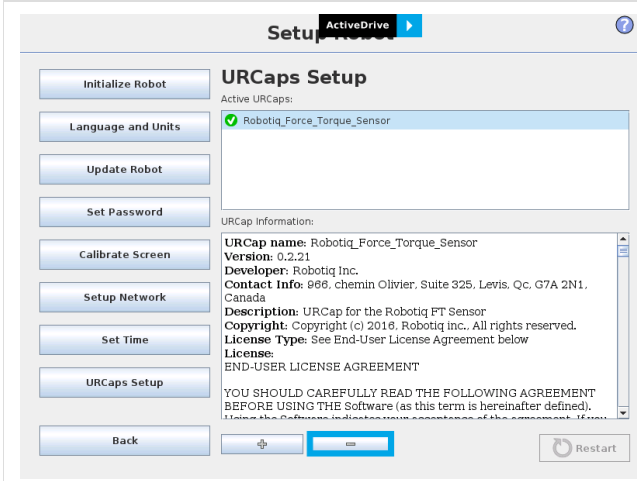

- In the Active URCaps text box, tap the Force Torque Sensor URCaps.
- The Sensor URCaps should be highlighted.
- Tap the minus button (-) to uninstall the URCaps.
- Restart Polyscope to complete the uninstallation process.

License Agreement

END-USER LICENSE AGREEMENT

YOU SHOULD CAREFULLY READ THE FOLLOWING AGREEMENT BEFORE USING THE Software (as this term is hereinafter defined). Using the Software indicates your acceptance of the agreement. If you do not agree with it, you are not authorized to use the Software.

IMPORTANT-READ CAREFULLY: This End-User License Agreement (the "Agreement") is a legal agreement between you and the Licensor (as this term is hereinafter defined), the licensor of the Software. This Agreement covers the Software. The Software includes any "on-line" or electronic documentation and all modifications and upgrades related thereto. By installing, or otherwise using the Software, you agree to be bound by the terms of this Agreement. If you do not agree to the terms of this Agreement, the Licensor cannot and does not license the Software to you. In such event, you must not use or install the Software.

1. Definition.

1. "UR" means Universal Robots A/S, a corporation incorporated under the laws of Denmark, having its registered office at Energivej 25, DK-5260 Odense S, which specializes into the conception, advanced manufacturing and sale of robotic products (the "UR's Business");
2. "Software" means any of the Licensor's softwares provided to its customers for the purposes mentioned in Sub-section 1.4 hereof including their modifications and upgrades and their related materials;
3. "Licensor" means Robotiq inc., a corporation incorporated under the laws of Quebec, having its registered office at 325-966 chemin Olivier, Lévis, Québec, Canada, G7A 2N1, which specializes into the conception, advanced manufacturing and sale of robotic products (the "Licensor's Business");
4. "End-User" means a customer authorized pursuant to this Agreement to install or use the Software in order to make a specific product from the Licensor's Products compatible and functional with a specific product of the UR's Product;
5. "Licensor's Products" means those products developed by the Licensor in the course of the Licensor's Business;
6. "UR's Products" means those products developed by UR in the course of the UR's Business;
7. "Licensor's Authorized Representatives" means and includes the Licensor and Licensor's authorized vendors, resellers, distributors and licensors;
8. "Purchase Agreement" means an agreement between the End-User and the Licensor pursuant to which the End-User purchased one or more of the Licensor's Products.

2. License. Subject to the terms and conditions hereof, the Licensor grants to the End-User a personal, temporary, non-exclusive, non-assignable and non-transferable and revocable license to use the Software in accordance with the terms and conditions hereof.
3. Software and Documentation. The Licensor may provide, if applicable, all documentation containing the detailed specifications for operation and use of the Software, which Software shall be used in accordance with such documentation. This documentation, if applicable, will be provided, wholly or in part, within (i) this Agreement, (ii) the Licensor's Web site <http://robotiq.com/> (iii) the Licensor's Products and the Purchase Agreement therewith, or (iv) any other agreement, document, support, whatsoever decided by the Licensor.

The use of the Software requires the Licensor's Products, UR's Products, compatible systems and certain software (which may require some expenses), may require periodical updating and may be affected by such elements. Most equipment will be compatible with the Software. However, the Software may not function on certain types of equipment.

4. Modifications and Upgrades. The Licensor shall be under no obligation to provide any upgrade or modification to the Software. However, the End-User shall be entitled to receive free of charge all modifications and upgrades of the Software provided by the Licensor if, at such time, the End-User is not in default in respect of any of its obligation contained herein. Such modifications and upgrades of the Software shall be installed by the End-User itself by consulting the Licensor's Website <http://robotiq.com/> where a link to proceed to such installation will be made available thereof. A new version of the Software shall not be covered by this Section 4 but shall require that a new End-User Software License Agreement be entered into between the Licensor and the End-User.
5. Fees. The grant by Licensor to the End-User of the present license shall be free to the extent that the End-User agrees and complies to the term and conditions herein at all time.
6. Maintenance. During the term of this Agreement, the Licensor will maintain the Software in an operable condition and will make available any corrections and improvements as are generally incorporated in the Software by the Licensor without additional charge to the End-User. The Licensor may temporarily and without notice suspend or limit access to the Software if necessary or desirable in order to maintain, restore, modify or repair any part of the Software or for any reason related to business. During such works, the Software will not be available but the Licensor undertakes to deploy its best efforts to perform such works at appropriate times and to limit any inconvenience arising therefrom.
7. Title to Software. The licensed Software is composed of confidential data and trade secrets and is proprietary to and constitutes trade secret information and intellectual property of the Licensor. Title and ownership rights to the Software, including the intellectual property rights related thereto, shall remain with the Licensor. The End-User agrees to maintain the confidential nature of the Software and related materials provided for the End-User's own internal use under this Agreement. The license granted herein does not include the right to sublicense to others, and may not be assigned to others, in whole or in part, without the prior written consent of the Licensor. The End-User may not or allow others to modify or prepare directive works, copy (except for normal backups for recovery purposes), reproduce, republish, reverse engineer, upload, post, transmit, or distribute, in any manner, the Software.
8. Restricted Use. The Software shall be used solely and exclusively by the End-User and its employees for the purpose mentioned in Sub-section 1.4 hereof. Any other use of the Software, including resell derivative modifications or extensions, is expressly prohibited.
9. Exclusion of Warranty on Software. The End-User expressly acknowledges and agrees that use of the Software is at the End-User sole

risk. The Software is provided "AS IS" and without warranty of any kind. THE LICENSOR AND THE LICENSOR'S AUTHORIZED REPRESENTATIVES DO NOT WARRANT THAT Software WILL BE FREE OF ERRORS AND YOU ACKNOWLEDGE THAT THE EXISTENCE OF ANY SUCH ERRORS DOES NOT CONSTITUTE A BREACH OF THIS AGREEMENT. TO THE EXTENT PERMITTED BY LAW LICENSOR AND LICENSOR'S AUTHORIZED REPRESENTATIVES EXPRESSLY DISCLAIM ALL WARRANTIES, EXPRESS OR IMPLIED, INCLUDING , BUT NOT LIMITED TO, THE IMPLIED WARRANTIES OF MERCHANTABILITY AND FITNESS FOR A PARTICULAR PURPOSE UNLESS OTHERWISE STATED HEREIN. LICENSOR AND LICENSOR'S AUTHORIZED REPRESENTATIVES DO NOT WARRANT THAT THE FUNCTIONS CONTAINED IN THE Software WILL MEET THE END-USER REQUIREMENTS OR THAT THE OPERATION OF THE Software WILL BE CORRECT. FURTHERMORE, LICENSOR AND LICENSOR'S AUTHORIZED REPRESENTATIVES DO NOT WARRANT OR MAKE ANY REPRESENTATIONS REGARDING THE USE OR THE RESULTS OF THE USE OF THE Software IN TERMS OF ITS CORRECTNESS, ACCURACY, RELIABILITY, OR OTHERWISE. NO ORAL OR WRITTEN INFORMATION OR ADVICE GIVEN BY LICENSOR AND LICENSOR'S AUTHORIZED REPRESENTATIVE SHALL CREATE A WARRANTY OR IN ANY WAY INCREASE THE SCOPE OF THIS WARRANTY. SHOULD THE Software PROVE DEFECTIVE IN YOUR TECHNOLOGY ENVIRONMENT, YOU ASSUME THE ENTIRE COST OF ALL NECESSARY SERVICING, REPAIR OR CORRECTION TO YOUR OWN TECHNOLOGY ENVIRONMENT.

10. Limitation of liability. TO THE MAXIMUM EXTENT PERMITTED BY LAW, LICENSOR AND LICENSOR'S AUTHORIZED REPRESENTATIVES SHALL NOT BE LIABLE FOR ANY INCIDENTAL OR CONSEQUENTIAL DAMAGES FOR BREACH OF ANY EXPRESS OR IMPLIED WARRANTY, BREACH OF CONTRACT, NEGLIGENCE, STRICT LIABILITY OR ANY OTHER LEGAL THEORY RELATED TO THE Software. SUCH DAMAGES INCLUDE, BUT ARE NOT LIMITED TO, LOSS OF PROFITS, LOSS OF REVENUE, LOSS OF DATA, LOSS OF USE OF THE PRODUCT OR ANY ASSOCIATED EQUIPMENT, DOWN TIME AND USER'S TIME, EVEN IF THE LICENSOR HAS BEEN ADVISED OF THE POSSIBILITY OF SUCH DAMAGES. IN ANY CASE, LICENSOR ENTIRE LIABILITY UNDER ANY PROVISION OF THIS AGREEMENT SHALL BE LIMITED TO THE AMOUNT ACTUALLY PAID IN RESPECT OF THE LICENSOR'S PRODUCTS PURCHASED BY THE END-USER PURSUANT TO A PURCHASE AGREEMENT.
11. Training, Maintenance and Support There is no entitlement to training, maintenance and support under this license unless otherwise specified in the Purchase Agreement or any other written agreement between the End-User and the Licensor. The End-User may provide the Licensor with details regarding any bug, defect or failure in the Software promptly and with no delay from such event; the End-User shall comply with the Licensor's request for information regarding bugs, defects or failures and furnish him with information, screenshots and try to reproduce such bugs, defects or failures upon Licensor's demand.
12. Expiration and Termination. The Licensor may terminate this Agreement for default by the End-User. This Agreement will also be automatically terminated upon the election of such by the Licensor or the official launch of the Software, whichever event comes first. Upon termination of this Agreement for any reason, the End-User shall promptly uninstall the Software on any UR's Products and Licensor's Products, computer, or server on which it has been installed, deliver to the Licensor all CDs, DVDs, magnetic tapes, cards, and other tangible items and materials embodying the Software, and return to the Licensor all copies thereof or destroy such copies and warrant in writing that all copies thereof have been destroyed. In the event of termination of this Agreement, all obligations of the parties under this Agreement due for performance on the date of termination shall survive the termination, and the party terminating shall not be liable to the other party for any damages arising out of the termination.
13. Miscellaneous.

1. This Agreement constitutes the entire understanding and agreement between the Licensor and the End-User and replaces any prior agreement relating to the same subject matter.
2. This Agreement shall be governed and construed in accordance with the laws of the province of Quebec and the federal laws of Canada applicable therein. Any legal action or proceeding between the Licensor and the End-User for any purpose concerning this Agreement or the parties' obligations hereunder shall be brought exclusively in a court of competent jurisdiction sitting in the judicial district of Trois-Rivières, Quebec.
3. The Licensor's failure to insist upon or enforce strict performance of any provision of this Agreement shall not be construed as a waiver of any provision or right. Neither the course of conduct between the parties nor trade practice shall act to modify any provision of this Agreement.
4. The Licensor may assign its rights and duties under this Agreement to any party at any time without notice to the End-User. The End-User may not assign this Agreement without the prior written consent of the Licensor.
5. If any part of this Agreement is null, illegal or non-enforceable, this Agreement shall be interpreted as if this part was never part of this Agreement.
6. The provisions of this Agreement are for the benefit of the Licensor and its officers, directors, employees, agents, licensors and suppliers. Each of these individuals or entities shall have the right to assert and enforce those provisions directly against the End-User on its own behalf. This Agreement is also for the benefit of, and binds, the End-User and its heirs, successors, legal representatives and permitted assigns.
7. Any rights not expressly granted herein are reserved.
8. The parties confirm that they have agreed that this Agreement and all related documents be drafted in English only. Les parties aux présentes confirment qu'elles ont accepté que la présente convention et tous les documents y afférents soient rédigés en anglais seulement.

3.8.2 UR Package without URCaps

If your Universal Robots' controller is not compatible with the URCaps package (see [Section 3.8](#) for compatibility), you can install the driver package and ActiveDrive toolbar separately. The driver package contains templates to access the Sensor's forces and torques values. The ActiveDrive toolbar allows to easily move the robot by hand guiding it. This section applies to Robotiq's software installation when not using URCaps.

The driver package and the ActiveDrive toolbar have separate installation processes. The driver package is independant from the ActiveDrive toolbar, but has to be installed beforehand if you wish to install the ActiveDrive toolbar.

Driver Package Installation

The URCaps package contains the driver package. Therefore, installing the URCaps package also installs the driver package. If you have installed the URCaps, you do not need to install the driver package. This section applies to Robotiq's software installation when not using URCaps. If you wish to install the URCaps package, refer to [Section 3.8.1](#).

Make sure your Polyscope version is up-to-date and that your controller is compatible with the driver package for UR (see [Section 3.8](#) for controller compatibility). To view your Polyscope version, go in the Home page of the teach pendant and tap the About button. A window containing the Universal Robots software version will pop up.

To install the driver package, follow this procedure :

- Download the Robotiq Force Torque Sensor software driver package (DFU-X.X.X) at support.robotiq.com.
- Extract the content of the .zip file on a blank USB flash drive.
- Plug the flash drive into the robot controller or teach pendant.
- Installation is automatic. The pendant screen will show installation status. Do not unplug the flash drive until the operation is completed.
- When a green "USB" text is shown, unplug the USB drive.

Calibration :

If the Force Torque Sensor is mounted on the robot for the first time, calibration must be performed. Refer to [Section 3.6.1](#) for the calibration procedure.

The Sensor must be recalibrated after each uninstall / install on the robot. Mounting screws will induce internal stress that needs to be compensated for. Not doing so will significantly affect the Sensor signal.

Testing the software package :

- Inside Polyscope, load the program test_sensor.urp located in the sensor folder and run it. The program will display pop-ups with the following information: Sensor firmware version, production year and serial number. The forces and torques readings for Fx, Fy, Fz, Mx, My and Mz are displayed in the Variables tab.

To get detailed information on how to program in Polyscope using the Force Torque Sensor signals, refer to [Section 4.1.3](#).

Removing the Package :

- Locate the uninstall.sh file provided in the driver package.
- Copy the file on a blank USB stick.
- Rename the file to urmagic_uninstall.sh.
- Plug the USB stick into the UR controller or teach pendant.
- Uninstallation is automatic.

ActiveDrive Toolbar Installation

Prior to installing the ActiveDrive toolbar, the Sensor Driver package should be installed.

The URCaps package contains the ActiveDrive toolbar. Therefore, installing the URCaps package also installs the toolbar. If you have installed the URCaps, you do not need to install the ActiveDrive toolbar. This section applies to Robotiq's software installation when not using URCaps. If you wish to install the URCaps package, refer to [Section 3.8.1](#).

Make sure your Polyscope version is up-to-date and that your controller is compatible with the driver package for UR (see [Section 3.8 f](#) or controller compatibility). To view your Polyscope version, go in the Home page of the teach pendant and tap the About button. A window containing the Universal Robots software version will pop up.

Verify that the Force Torque Sensor is aligned with the robot arm using the dowel pin, or at least make sure the holes are aligned. This ensures that the Sensor's axes are aligned with the robot's and that the ActiveDrive will work correctly.

To install the ActiveDrive toolbar :

- Visit support.robotiq.com and download the latest ActiveDrive toolbar installer (ADU-X.X.X).
- Extract the files on a blank USB key.
- Connect the USB in the Universal Robots' teach pendant or controller.
- Installation is automatic. The pendant's screen will show installation status.
- Do not remove the USB key before the installation is completed.
- Once installation is completed, the ActiveDrive toolbar button will appear on the teach pendant's screen after a short delay.

To get detailed information on how to use the ActiveDrive toolbar, refer to [Section 4.1.1](#).

4. Software

The following sub-sections provide instructions for installation of the software package on various platforms. This allows you to get data from the FT Sensor.

Tip

Section 4. information on software is identical for both versions of the FT Sensor.

- [Section 4.1](#) and sub-sections refers to the control and programming for Universal Robots.
- [Section 4.2](#) and sub-sections detail the installation of an open source development package, which can be adapted according to the users' needs. It currently functions with Windows and Linux.
- [Section 4.3](#) links to ROS.
- [Section 4.4](#) explains the Demo Software
- [Section 4.5](#) will detail the use of serial communication in generic applications

4.1 Control with Universal Robots

The URcaps Package contains many features to program and control the robot's arm using the Sensor's forces and torques readings. The package provides:

- [ActiveDrive](#) toolbar;
- [Path](#) recording node;
- [Driver](#) package.

4.1.1 ActiveDrive Toolbar

The ActiveDrive toolbar is automatically installed with the Force Torque Sensor URCaps Package. It enhances the guiding mode on Universal Robots by allowing the robot to be hand guided smoothly and easily to a waypoint. The ActiveDrive feature is a great way to assist the Path recording described in [Section 4.1.2](#) by hand guiding the robot while recording a path.

The Force Torque Sensor URCaps Package contains the ActiveDrive toolbar. Therefore, the toolbar is automatically installed with the URCaps Package. The ActiveDrive toolbar can be installed and used without the URCaps Package (see [Section 3.8.2](#) for information on how to install the toolbar without the URCaps).

Verify that the Force Torque Sensor is aligned with the robot arm using the dowel pin. This ensures that the Sensor's axes are aligned with the robot and that the ActiveDrive feature will work correctly.

Overview

Toolbar collapsed :



Tap the ActiveDrive button to expand the toolbar.

Toolbar expanded :















Tap the mode selector to expand.

ActiveDrive modes expanded :



Features

Primary icon	Secondary icon	Functionality name	Description
		ActiveDrive	Tap to toggle between expanded and collapsed ActiveDrive toolbar. When grey, the functionality is not available. Tap the button to see why it is not available.
		Start / Stop	Tap to start or stop ActiveDrive. ActiveDrive will automatically turn off after 30s of inactivity. When started, ActiveDrive allows you to move the robot freely by applying forces on robot's end-effector. This is different from the Free Drive feature on the robot, where you can move the robot arm.
		Modes	Shows the current ActiveDrive mode. When tapping the icon, the available modes will appear and you can change to a different mode. ActiveDrive modes allow you to restrain the robot to specific movements.
		Free	Free motion: all translations and rotations are allowed.
		Scara	SCARA-style motion: all translations and horizontal rotation (twist) are allowed.
		Translation	Translation motion: only translations are allowed. No rotation of the robot is possible in this mode.
		Plane	Plane motion: horizontal translations and horizontal rotations (twist) are allowed (no vertical motions are allowed).
		Drift Control	Tap this button to stop the robot from drifting (resets the Sensor's offset).
		Speed	Motion speed control is toggled between fast and slow, allowing precise movement in slow motion. The Force Torque Sensor will switch to slow speed automatically whenever high forces are detected, for example, during an impact with an object.
		Square robot	Aligns the tool center point (TCP) orientation with the robot base. Tap and hold this button to automatically move the end-effector to the closest orthogonal orientation of the base axis system (just try it, you will see!).

Error Messages Overview

The ActiveDrive toolbar will be automatically collapsed and be grayed whenever one of the following situations occurs. In such cases, by tapping the ActiveDrive button, the following messages will appear:

- Message:

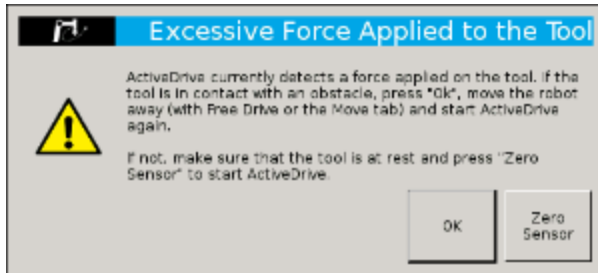

- Solution:
 - Starting ActiveDrive while an excessive force is applied to the tool:
 - Determine if an external force is applied to the end-effector. If it is the case, tap "OK" and move the robot away from the obstacle (with Free Drive or Move tab), or remove any external forces and start ActiveDrive again.
 - If no external forces are applied, tap "Zero Sensor".

• Message:

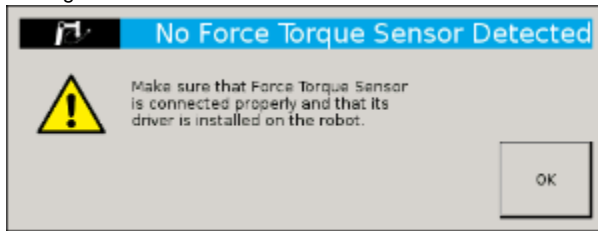

- Solution:
 - Force Torque Sensor is detected: Check the Force Torque Sensor's connection. Make sure the USB adapter and all the wires are well connected. Also verify the Sensor's LED status (see Section 3.7).

• Message:

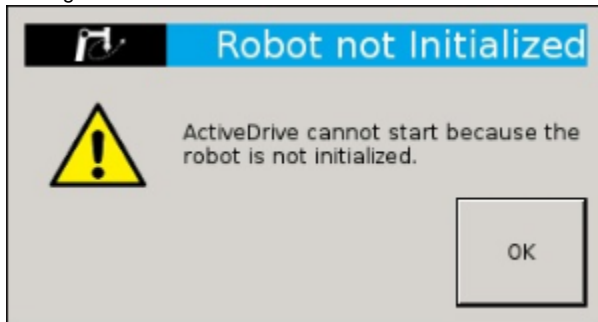

- Solution:
 - The robot is not initialized: Tap "OK" and go to Polyscope's home page. Tap Setup Robot and go in Initialize Robot to start the robot.

• Message:

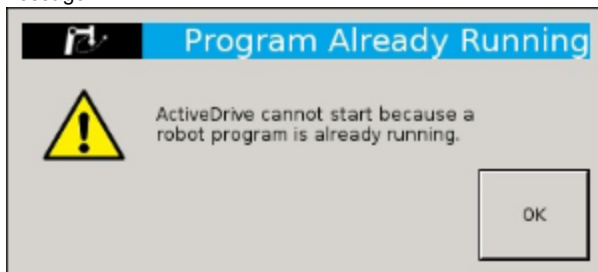

- Solution:
 - A program is already running: The ActiveDrive toolbar cannot be used while a program is running. Stop the program to enable the ActiveDrive feature.

• Message:

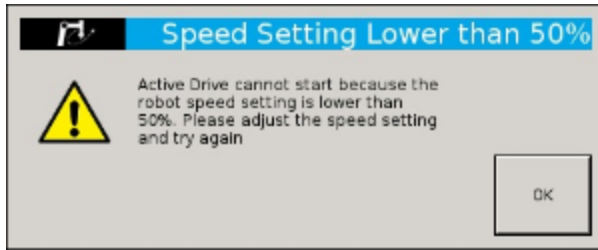

- Solution:

- The speed setting of the robot is lower than 50%: The robot's speed setting should be greater than 50%. Modify the speed setting in the robot's program with the slider.

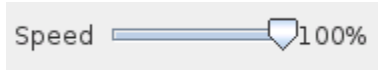

- Message:

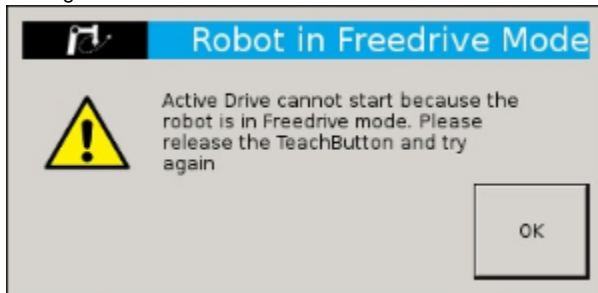



- Solution:

- If the Freedrive button is pressed: The ActiveDrive mode cannot be used when the Free Drive mode is on. Make sure you are not pressing on the teach pendant's Teach button when trying to use the ActiveDrive toolbar.

4.1.2 Path Recording

The Force Torque Sensor URCaps Package adds a Path feature in Polyscope which can be used to record paths directly by moving the robot. The ActiveDrive toolbar is a great tool to use while recording a path, as it is an easy way to hand guide the robot's end-effector. Path recording can be used for specific processes requiring complex paths (polishing, gluing, etc.) or more generally for any useful case that would require programming a high number of waypoints. The Path node offers options to modify the recorded path to change its speed and play the path backwards or relative to a variable start position.

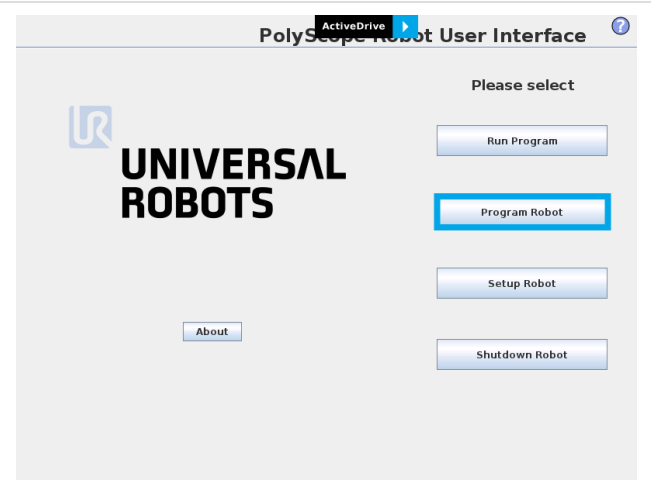
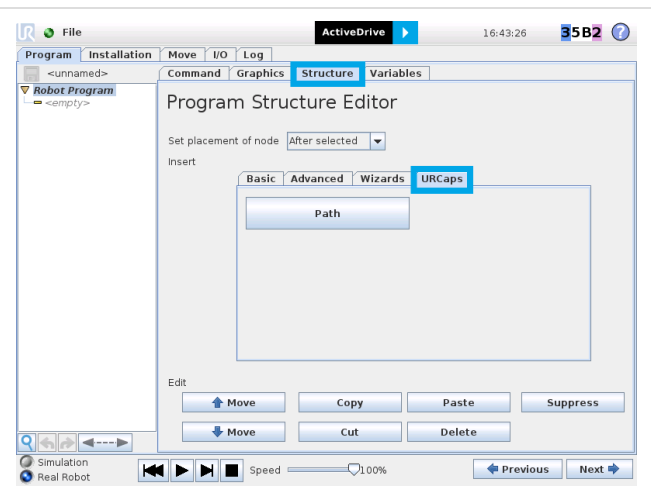
How to add and record a path

	<ul style="list-style-type: none"> • Tap Program Robot • Open an empty program or load a template.
	<ul style="list-style-type: none"> • Go in the Structure tab. • Go in the URCaps tab. • Tap the Path button.
	<ul style="list-style-type: none"> • Go in the Command tab to record and edit a path.

Overview



	<p>Path time and speed information. Warning sign is displayed whenever a setting results in a duration different than the original path duration.</p>
	<p>Path recording and visualization.</p>
	<p>Path speed slider.</p>
	<p>Path options.</p>
	<p>Warning section. Displayed whenever a setting results in a duration different than the original path duration.</p>

	<p>When a Path node is empty (no path recorded), the only available button is to record.</p>
--	--

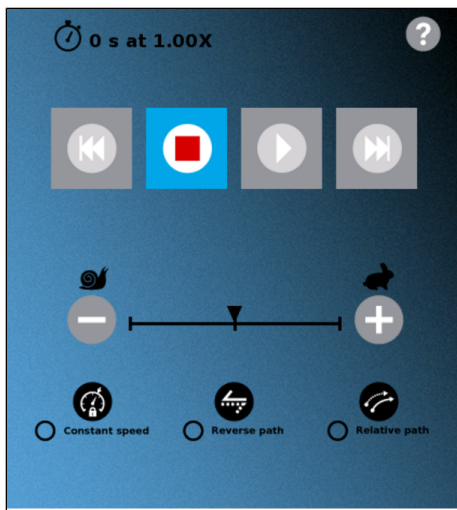

While recording a path, the only available button is to stop the recording.

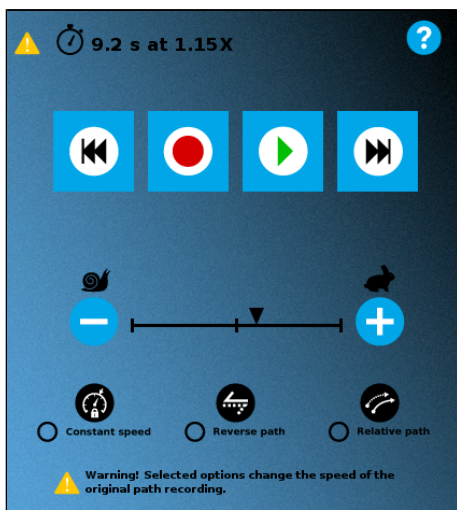



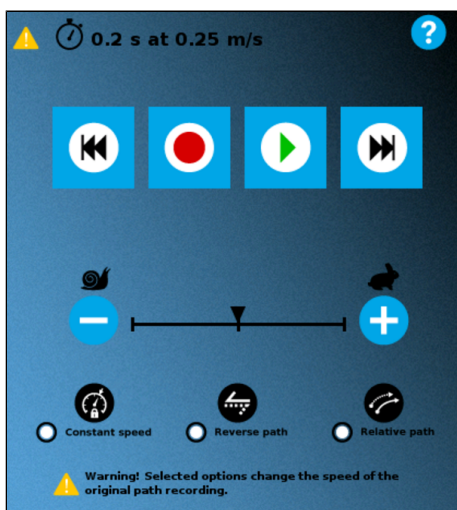





When the speed of the original recording is modified using the speed slider, a warning message appears and the path time and speed information is updated.



When a path option is selected, a warning messages appears and the path time and speed information is updated.

Features*

Primary icon	Secondary icon	Functionality name	Description
		Start/Stop recording	Starts and stops the path recording.
		Navigate to path's start	Press and hold in order to move the robot at the path's start.
		Navigate to path's end	Press and hold in order to move the robot at the path's end.
		Play path	Press and hold in order to move the robot to the path's start and play the path as it will be executed in the program.
		Enable constant speed	If selected, the path is modified to play at a constant tool speed (linear speed at the tool center point) defined by the Path speed slider's position. With this option, all pauses and hesitations (dead times) in the path will be removed.
		Enable reverse path	If selected, the recorded path will be played backwards in the program. It can be useful if a path is copied and played backwards, resulting in a path played back and forth.
		Enable relative path	If selected, the path will be played relative to the current robot position when the program enters the path instruction. This effectively offsets all the recorded path and can be used to: <ul style="list-style-type: none"> • correct a path (for example adding a vertical distance on the whole path); • accommodate a variable object position (for example when the object is located by a vision system).
		Decrease path speed	Changes the Path speed slider's position. If constant speed is selected, decreasing/increasing directly changes the tool speed on the path (from 0.05m/s to 1.25m/s). If constant speed is not selected, it changes the speed amplification factor (from 0.5X to 2X). Please note that the recorded path will be played at the requested speed but is subject to a joint speed saturation (i.e. for any point of the path, the maximum speed of the robot will be used in case it is lower than the requested speed).
		Increase path speed	
		Path speed warning	"Warning! Selected options change the speed of the original path recording." Displayed whenever a setting results in a duration different than the original path duration.

* When an icon is greyed, it means it is unavailable.

If you tap the record button when a path is already recorded in a node, a warning pop-up window will ask if you want to overwrite the path (tap "OK") or keep the previously recorded path (tap "Cancel").

4.1.3 Driver Package to access Force Torque Signal

The driver package installed with the URCaps Package (or standalone) allows the use of the Sensor's signals directly inside a Polyscope program. This can be useful to limit the force applied by the robot, to log the force measured during product testing or to adapt a process using force signal, for example. For this purpose, the driver package includes program templates and examples to help you get started with your own custom program.

The Force Torque Sensor URCaps Package contains the Driver Package. Therefore, it is automatically installed with the URCaps Package. The Driver Package can also be installed and used without the URCaps Package (see [Section 3.8.2](#) for information on how to install the Driver package without the URCaps).

Examples Provided

When the driver package DFU-X.X.X or the Sensor's URCaps Package is installed, demo scripts will be available.

Demo_force_push_move.script

This script moves the robot forward in the z-axis until a force is reached on this axis:

- The robot stops when the Fz_max threshold is reached. The threshold is set to 15N in the demo script;
- Fz_tolerance is the tolerance for "noise" on the signal, set to 2.5N.

Always leave a tolerance on the force reading. The minimum tolerance is +/- 0.5 N. For instance, a noise level set under 1 N will result in erratic results. In this example, 2.5 N is used because the Sensor and the tool cables can have an effect on the Sensor as well.

Demo_force_push_release.script

This script applies a force along the z-axis and moves the robot arm :

- Robot moves to a defined position;
- Robot applies force on a surface equal to the Fz_applied variable;
- Threshold force is set with Fmax;
- Robot will return to Home position when Fmax is reached.

Demo_force_twist_release_script

This script moves the robot's wrist in a rotational movement to apply a certain level of torque in the z-axis then move the robot arm :

- Robot moves to a defined position;
- Robot applies a torque Mz at the wrist;
- Threshold moment is set with Mmax;
- Robot returns to Home position when Mmax is reached.

Custom Programs

You can create your own program using the Force Torque Sensor signals by following this procedure :

- In the list of provided samples, open "sensor_template.urp".
- Push "play" and check the "Variables" tab.
 - You will see Sensor variables Fx, Fy, Fz, Mx, My, Mz.
 - You can verify the readings by applying force to the Sensor and observe the response.
- Add your instructions in the robot program section.
 - For example, you can command the robot to move until you read a certain threshold of force.
 - The program instructions (robot motion, logic, etc.) can be added after the "Script: accessor_capt" line and you can start building the program as it is normally done with Polyscope.

To simplify Sensor integration, load the "sensor_template.urp" and use a copy to start programming. The program initializes the Sensor variables, required to be used globally, runs a script which starts a thread to read Sensor data and updates variables. The script also contains some subprograms to interact with the Sensor data.

The Sensor's data returns the following variables: Fx, Fy, Fz, Mx, My, Mz. When a variable list is shown (for example when programming an "IF" statement), they will be available in the scroll box. The variables are floats with forces being in Newtons (N) and moments being in Newtons-meters (Nm). The variables are updated automatically by the Sensor thread.

Calibrating the zero of the Sensor is essential to compensate for tool weight and other factors that could affect the readings. It is recommended to use the "rq_set_zero" subprogram in the program to set the readings to zero before applying/measuring force or torque. Use the "rq_set_zero" subprogram when no force is applied on the Sensor and with the same orientation you want to use for further readings

4.2 Development package

The Robotiq Force Torque Sensor development package can be downloaded at support.robotiq.com.

Distribution License

The development package is distributed under the New BSD license, which is a permissive free software license. In short, the provided code can be used in any project without any restriction regarding its use (commercial or not). If it is included in a software, this software does not need to be open-source. However, the code is provided "as is" without any liability from Robotiq and some restrictions apply regarding the distribution of the code and the use of the Robotiq name.

The terms of the license (included in each source file) are described here:

```
Software License Agreement (BSD License)
```

```
Copyright (c) 2014, Robotiq, Inc. All rights reserved.
```

```
Redistribution and use in source and binary forms, with or without  
modification, are permitted provided that the following conditions are met:
```

- Redistributions of source code must retain the above copyright notice, this list of conditions and the following disclaimer.
- Redistributions in binary form must reproduce the above copyright notice, this list of conditions and the following disclaimer in the documentation and/or other materials provided with the distribution.
- Neither the name of Robotiq, Inc. nor the names of its contributors may be used to endorse or promote products derived from this software without specific prior written permission.

```
THIS SOFTWARE IS PROVIDED BY THE COPYRIGHT HOLDERS AND CONTRIBUTORS  
"AS IS" AND ANY EXPRESS OR IMPLIED WARRANTIES, INCLUDING, BUT NOT  
LIMITED TO, THE IMPLIED WARRANTIES OF MERCHANTABILITY AND FITNESS  
FOR A PARTICULAR PURPOSE ARE DISCLAIMED. IN NO EVENT SHALL THE  
COPYRIGHT OWNER OR CONTRIBUTORS BE LIABLE FOR ANY DIRECT, INDIRECT,  
INCIDENTAL, SPECIAL, EXEMPLARY, OR CONSEQUENTIAL DAMAGES (INCLUDING,  
BUT NOT LIMITED TO, PROCUREMENT OF SUBSTITUTE GOODS OR SERVICES;  
LOSS OF USE, DATA, OR PROFITS; OR BUSINESS INTERRUPTION) HOWEVER  
CAUSED AND ON ANY THEORY OF LIABILITY, WHETHER IN CONTRACT, STRICT  
LIABILITY, OR TORT (INCLUDING NEGLIGENCE OR OTHERWISE) ARISING IN  
ANY WAY OUT OF THE USE OF THIS SOFTWARE, EVEN IF ADVISED OF THE  
POSSIBILITY OF SUCH DAMAGE.
```

4.2.1 Linux

Package Files - Description

The development package is structured with the following files and directories architecture (non-Linux files and directories are ignored in this section):

- src: contains the source files common to all platforms
- obj: used during compilation for the object files related to the common sources
- Linux: contains Linux specific files
 - bin: contains the binary files
 - src: contains the source files common to all platforms
 - main.c : application source file which can be modified by the user
 - obj: contains all the object files after they are compiled
- Makefile: file containing the rules to compile the sensor driver using Make

When started, the provided software will scan all ports in the system (ttySx and ttyUSBx) to find a compatible Robotiq device. It uses the Linux utility "fuser" to determine if the port is already opened. This section of code can be modified by the user if necessary to avoid the scanning of ports (for example, if another device would become confused when receiving a message that it cannot understand).

Procedure to Compile and Test the Provided Source Code

This procedure explains how to compile the source code and verify that the sensor data is properly read.

1. Unzip the package in the home folder, for example in the folder **~/driver/**
2. Open a terminal and enter the package directory using the following command:

```
rd@debian:~/ $ cd driver
```

3. Use Make to compile the application:

```
rd@debian:~/ $ make linux
```

4. In order to have access to the virtual serial COM port, add the used *username* to the group *dialout*.

```
rd@debian:~/ $ sudo usermod -a -G dialout username
```

5. It is required to logout (or reboot) the session in order for the group change to become effective.
6. Make sure that the sensor is properly powered and that the data signals are connected to the development PC using the provided RS-485 to USB converter. A new device named ttyUSBx should be present in /dev, which can be verified with the following command:

```
rd@debian:~/ $ ls -l /dev | grep ttyUSB
```

7. In a terminal, go to the **~/driver/Linux/bin** folder and execute the demo application using the following command:

```
rd@debian:~/driver/Linux/bin/ $ ./driverSensor
```

8. After 1-2 seconds, the sensor data should start showing up in the terminal as a vector of 6 floats with data in the (Fx, Fy, Fz, Mx, My, Mz) format.

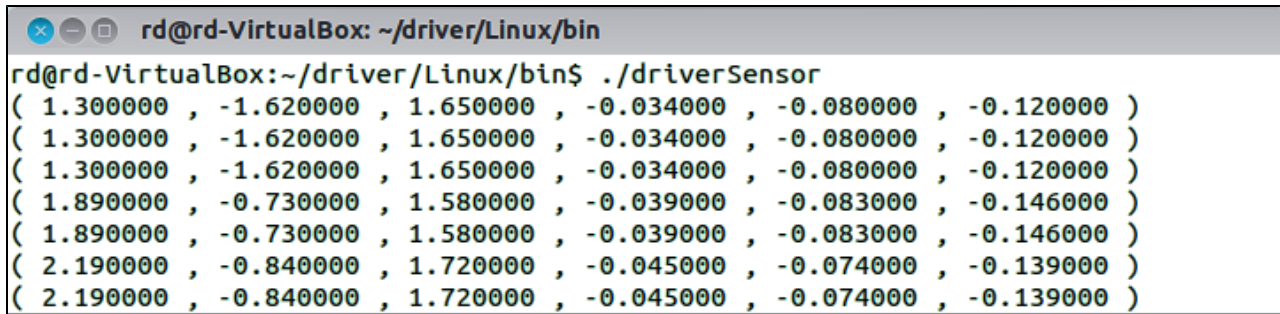
A terminal window titled 'rd@rd-VirtualBox: ~/driver/Linux/bin' showing the execution of './driverSensor'. The output consists of seven lines of floating-point data, each enclosed in parentheses and separated by commas. The data values are: (1.300000 , -1.620000 , 1.650000 , -0.034000 , -0.080000 , -0.120000), (1.300000 , -1.620000 , 1.650000 , -0.034000 , -0.080000 , -0.120000), (1.300000 , -1.620000 , 1.650000 , -0.034000 , -0.080000 , -0.120000), (1.890000 , -0.730000 , 1.580000 , -0.039000 , -0.083000 , -0.146000), (1.890000 , -0.730000 , 1.580000 , -0.039000 , -0.083000 , -0.146000), (2.190000 , -0.840000 , 1.720000 , -0.045000 , -0.074000 , -0.139000), and (2.190000 , -0.840000 , 1.720000 , -0.045000 , -0.074000 , -0.139000).

```
rd@rd-VirtualBox:~/driver/Linux/bin$ ./driverSensor
( 1.300000 , -1.620000 , 1.650000 , -0.034000 , -0.080000 , -0.120000 )
( 1.300000 , -1.620000 , 1.650000 , -0.034000 , -0.080000 , -0.120000 )
( 1.300000 , -1.620000 , 1.650000 , -0.034000 , -0.080000 , -0.120000 )
( 1.890000 , -0.730000 , 1.580000 , -0.039000 , -0.083000 , -0.146000 )
( 1.890000 , -0.730000 , 1.580000 , -0.039000 , -0.083000 , -0.146000 )
( 2.190000 , -0.840000 , 1.720000 , -0.045000 , -0.074000 , -0.139000 )
( 2.190000 , -0.840000 , 1.720000 , -0.045000 , -0.074000 , -0.139000 )
```

Figure 4.1.1.1 : Sensor Data Acquisition.

Adapt to a User Application

In practice, the provided source code will be adapted to either: be incorporated with a custom application or to communicate with one. At this point, the main.c file should be adapted according to the guideline comments inserted in the code.

Please note that Robotiq can only support our customers in making sure they can compile and test the provided code as *is*.

No support can be provided for the integration of the provided source code into a custom application.

4.2.2 Windows

Package Files - Description

The development package is structured with the following files and directories architecture (non-Windows files and directories are ignored in this section):

- src: contains the source files common to all platforms
- obj: used during compilation for the object files related to the common sources
- Windows: contains Windows specific files
 - bin: contains the binary files
 - src: contains the source files common to all platforms
 - main.c : application source file which can be modified by the user
 - obj: contains all object files after they are compiled
 - Data_logger: contains an application (and its source code) to log data from the sensor
 - compiler.bat: script which automates the settings for the environment variables and the compilation of the example application
- Makefile: file containing the rules to compile the sensor driver using Make

Procedure to Compile and Test the Provided Source Code

This procedure explains how to install MinGW, compile the provided source code and verify that the sensor data is properly read.

1. Unzip the package in the desired directory.
2. If it is not already installed, download MinGW at <http://www.mingw.org/>. Download the installer "mingw-get-setup.exe".
3. Install MinGW by running "mingw-get-setup.exe" and save the default installation path.
4. Open "MinGW installation manager".
5. Select "mingw-developer-toolkit" in the "Basic setup" tab and click "Mark for Installation".
6. Select "mingw32-binutils" in the "All packages" tab and click "Mark for Installation".
7. In the menu "Installation", click "Apply changes". This will install the required packages to compose the software using Make.
8. In the Windows directory, run the compiler.bat file. This will build your application.
9. Run the application "driverSensor" located in the "Windows/bin/" folder.
10. After 1-2 seconds, the sensor data should start showing up in the command window as a vector of 6 floats with data in the (Fx, Fy, Fz, Mx, My, Mz) format.

```

C:\Users\rd\Desktop\driver\Windows\bin\driverSensor.exe
< 1.760000 , -2.690000 , 0.650000 , 0.044000 , -0.031000 , -0.156000 >
< 1.760000 , -2.690000 , 0.650000 , 0.044000 , -0.031000 , -0.156000 >
< 1.740000 , -2.630000 , 0.580000 , 0.040000 , -0.034000 , -0.174000 >
< 1.740000 , -2.630000 , 0.580000 , 0.040000 , -0.034000 , -0.174000 >
< 2.080000 , -2.910000 , 0.950000 , 0.043000 , -0.032000 , -0.167000 >
< 1.490000 , -2.550000 , 0.870000 , 0.046000 , -0.036000 , -0.164000 >
< 1.490000 , -2.550000 , 0.870000 , 0.046000 , -0.036000 , -0.164000 >
< 1.160000 , -3.070000 , 0.570000 , 0.041000 , -0.027000 , -0.164000 >
< 1.160000 , -3.070000 , 0.570000 , 0.041000 , -0.027000 , -0.164000 >
< 1.540000 , -2.870000 , 0.860000 , 0.043000 , -0.011000 , -0.173000 >

```

Figure 4.1.2.1 : Sensor Data Acquisition Under Windows.

Adapt to a User Application

In practice, the provided source code will be adapted to either: be incorporated with a custom application or to communicate with one. At this point, the main.c file should be adapted according to the suggested comments inserted in the code.

Please note that Robotiq can only support our customers in making sure they can compile and test the provided code as *is*.

No support can be provided for the integration of the provided source code into a custom application.

4.3 ROS

ROS is an open-source framework for developing robot software. The Robotiq Force Torque Sensor has a ROS package which allows you to read the sensor data and bias the sensor. The ROS package is called `robotiq_force_torque_sensor` and is part of the [ROS-Industrial repository](#).

Procedure to install and test the Robotiq Force Torque Sensor package

Note

This tutorial assumes that ROS is already installed. These instructions have been tested on ROS Hydro and ROS Indigo with an Ubuntu system.

1. Create a ROS workspace according to this tutorial: <http://wiki.ros.org/ROS/Tutorials/InstallingandConfiguringROSEnvironment>
2. Checkout the `robotiq_force_torque_sensor` package in the `src/` folder.
3. Go back into the workspace root and execute the following command in a terminal:

```
rd@ROS:~/ $ catkin_make robotiq_force_torque_sensor_generate_messages
```

4. Run the following command to build your package:

```
rd@ROS:~/ $ catkin_make
```

5. In order to allow your Linux user to open the serial port, run the following command as a superuser:

```
rd@ROS:~/ $ usermod -a -G dialout YOURUSERNAME
```

6. Logout and then re-login to the session to activate the user access modification.
7. Go back into the workspace root.
8. For each terminal proceed with the following steps, source the Catkin workspace using this command:

```
rd@ROS:~/ $ source devel/setup.bash
```

9. In its own terminal, start `roscore`:

```
rd@ROS:~/ $ roscore
```

10. In its own terminal, start `rq_sensor`:

```
rd@ROS:~/ $ rosrun robotiq_force_torque_sensor rq_sensor
```

11. In its own terminal, start `rq_test_sensor` (which displays the data and intermittently biases the sensor):

```
rd@ROS:~/ $ rosrun robotiq_force_torque_sensor rq_test_sensor
```

4.4 Visual Demo Software

The Visual Demo Software is used to demonstrate the ability of the FT Sensor to read force and momentum. It is not intended to be used for

programming or to save or use data. It can also be used to calibrate the Sensor; see Section 3.6.2 for the calibration procedure.

Software Package Installation

1. Make sure that you have the latest version of the Visual Demo Software, which can be found at support.robotiq.com.

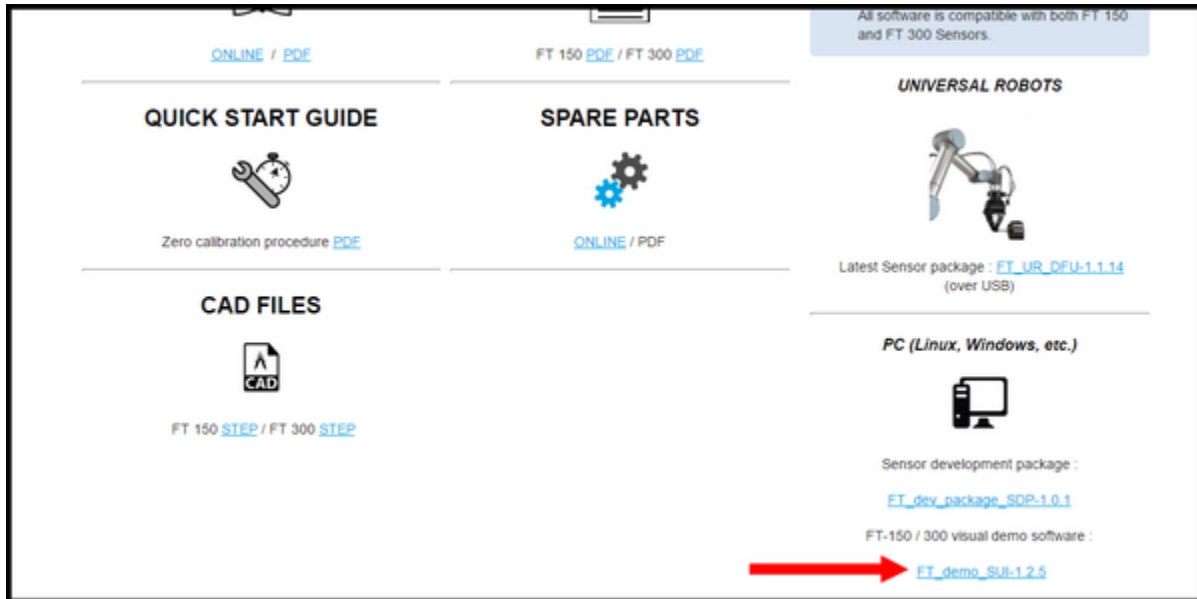

2. Copy all the files of this folder onto a PC.
3. Connect the USB connector to the converter attached to the PC. **Important : The Sensor must NOT be powered at this time.**
4. Wait while the driver(s) install. After all the drivers have been installed.
5. Plug the Sensor cable into the Sensor.
6. Connect the Sensor cable to the power supply.
7. Launch the demo application.

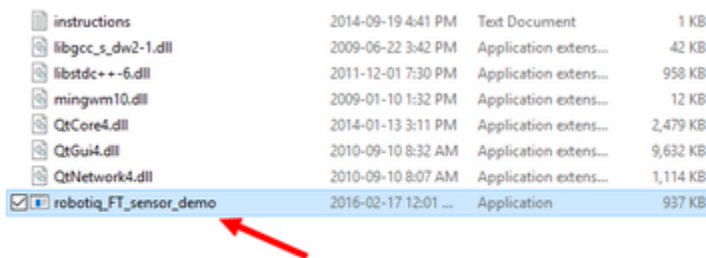

8. You should see a COM port in green with a serial number, showing the Sensor connected to the PC. Click on it.

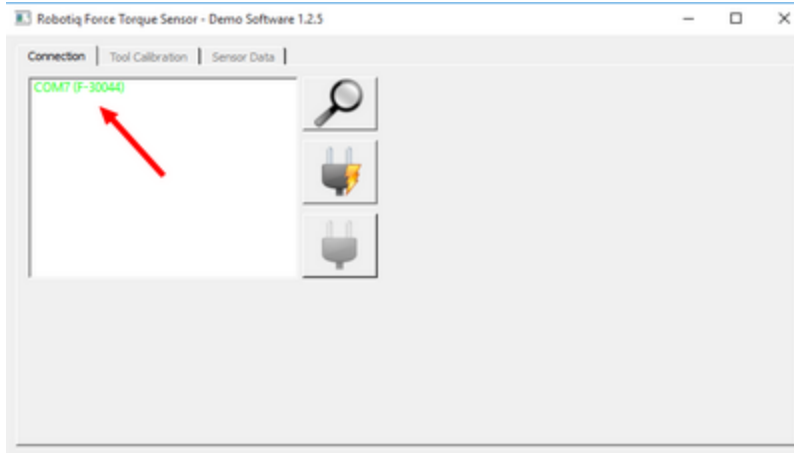

By going into the "Sensor Data" tab, you can now see in real time the force and moment applied on the FT Sensor.

4.5 Serial communication

The FT Sensor uses two communication modes, Modbus RTU and data stream. The Modbus RTU communication mode is used to obtain information on the Sensor, like its firmware version. The data stream mode is used to obtain data from the Sensor.

Info

It is recommended to use the FT Sensor data stream to obtain faster data acquisition.

Note

Modbus RTU can be used to obtain data, but will result in a slower data acquisition frequency.

Info

In both modes, force and torque data from the Sensor will be in 16-bits signed integer format.

Modbus RTU:

The Modbus RTU serial communication configuration parameters are:

Parameter	Value
Baudrate (bps)	19200
Data bits	8
Stop bit	1
Parity	none
Slave ID	9

In Modbus RTU you can obtain the following information:

Information	Register
Production year	514
Serial number	510 to 513
Force X (N) = value / 100	180
Force Y (N) = value / 100	181
Force Z (N) = value / 100	182

Moment X (Nm) = value / 1000	183
Moment Y(Nm) = value / 1000	184
Moment Z (Nm) = value / 1000	185
Acceleration X (g) = value / 1000	190
Acceleration Y (g) = value / 1000	191
Acceleration Z (g) = value / 1000	192

Data Stream:

Data stream mode is the recommended method of obtaining data from the Sensor. Once initiated, the Sensor will stream force and moment data continuously until communication is interrupted by the user.

Tip

To **start the data stream**, write 0x0200 in register 410.

For a setup over Universal Robots, Data stream will be accessible on TCP port 63351 of your machine.

Tip

With a Universal Robot, you can access the data stream using the documentation available at UR : [Remote Control Via TCP/IP - 16496](#)

To stop the data stream, communication must be interrupted by sending a series of 0xff characters to the Sensor. Sending for about 0.5s (50 times) will ensure that the Sensor stops the stream.

When the stream is started, 16 bytes messages are sent by the sensor at 100Hz using this format:

<0x20><0x4e><LSB_data1><MSB_data1> ... <LSB_data6><MSB_data6><LSB_crc><MSB_crc>

With dataX being a 16-bits signed integer defined as:

Data	Value meaning
data1	Fx * 100 (N)
data2	Fy * 100 (N)
data3	Fz * 100 (N)
data4	Mx * 1000 (Nm)
data5	My * 1000 (Nm)
data6	Mz * 1000 (Nm)

The CRC is computed using a standard 16-bits modbus CRC (see http://www.ccontrols.com/w/How_to_Compute_the_Modbus_RTU_Message_CRC)

5. Specifications

The following sections provide data on the various specifications of the Robotiq Force Torque Sensor.

- Section 5.1 details the technical dimensions of the sensor.
- Section 5.2 details the mechanical specifications.
- Section 5.3 covers signal specifications (data acquisition).
- Section 5.4 specifies electrical rating.
- Section 5.5 covers the technical dimensions of the sensor coupling options.

5.1 Technical dimensions

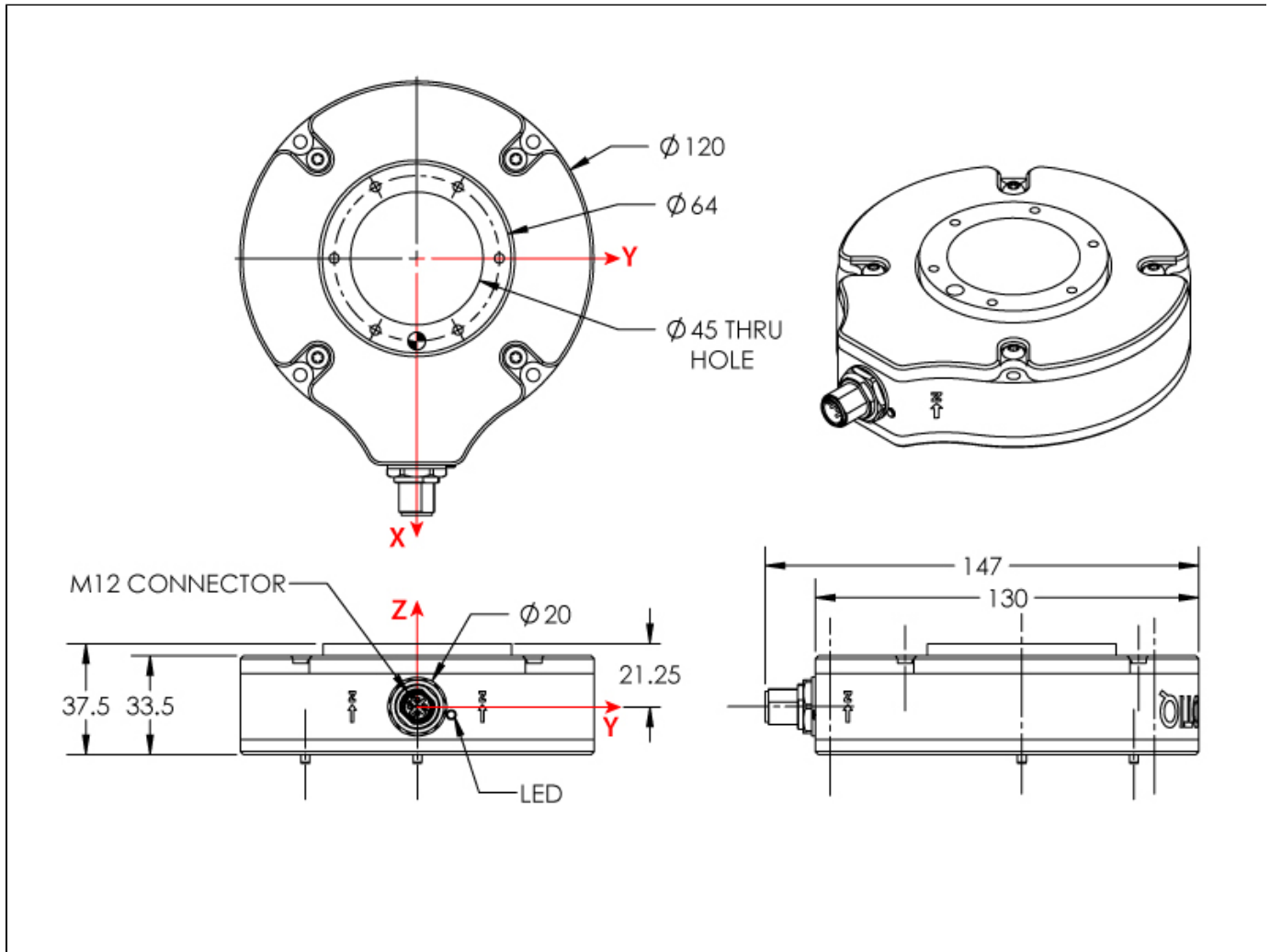

Figure 5.1.1 : Robotiq FT 150 Sensor general technical dimensions.

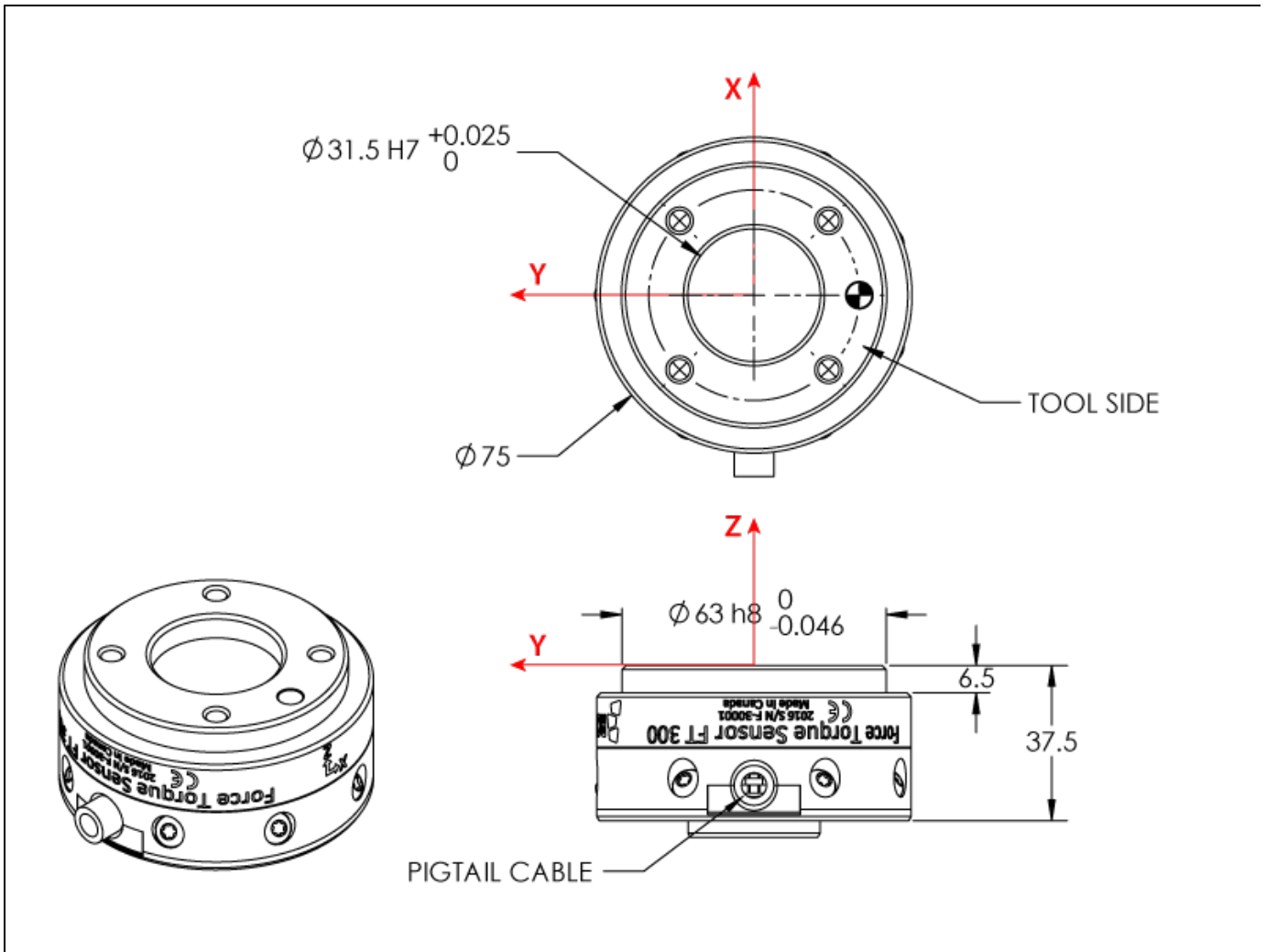

Figure 5.1.2 : Robotiq FT 300 Sensor general technical dimensions.

Info

Reminder: Measures in millimeters.

5.1.1 Robot side bolt pattern

Figure 5.1.1.1 shown below describes the bolt pattern for fixation of the FT 150 Sensor onto the robot or other support.

- M4 screw clearance is meant to fix the Sensor on the coupling that is attached to the robot.
 - Screw heads are present on the non-robot side or the tool side of the Sensor.
- Both indexing pins are M3 dowel pins press-fitted into the Sensor.

Note

M3 dowel pins are normally pressed onto the FT 150 sensor when delivered. If press fitting of the M3 dowel pins is required, do not support the FT 150 Sensor from the inner ring during this operation. Failure to adhere to this requirement will disrupt the calibration of the Sensor.

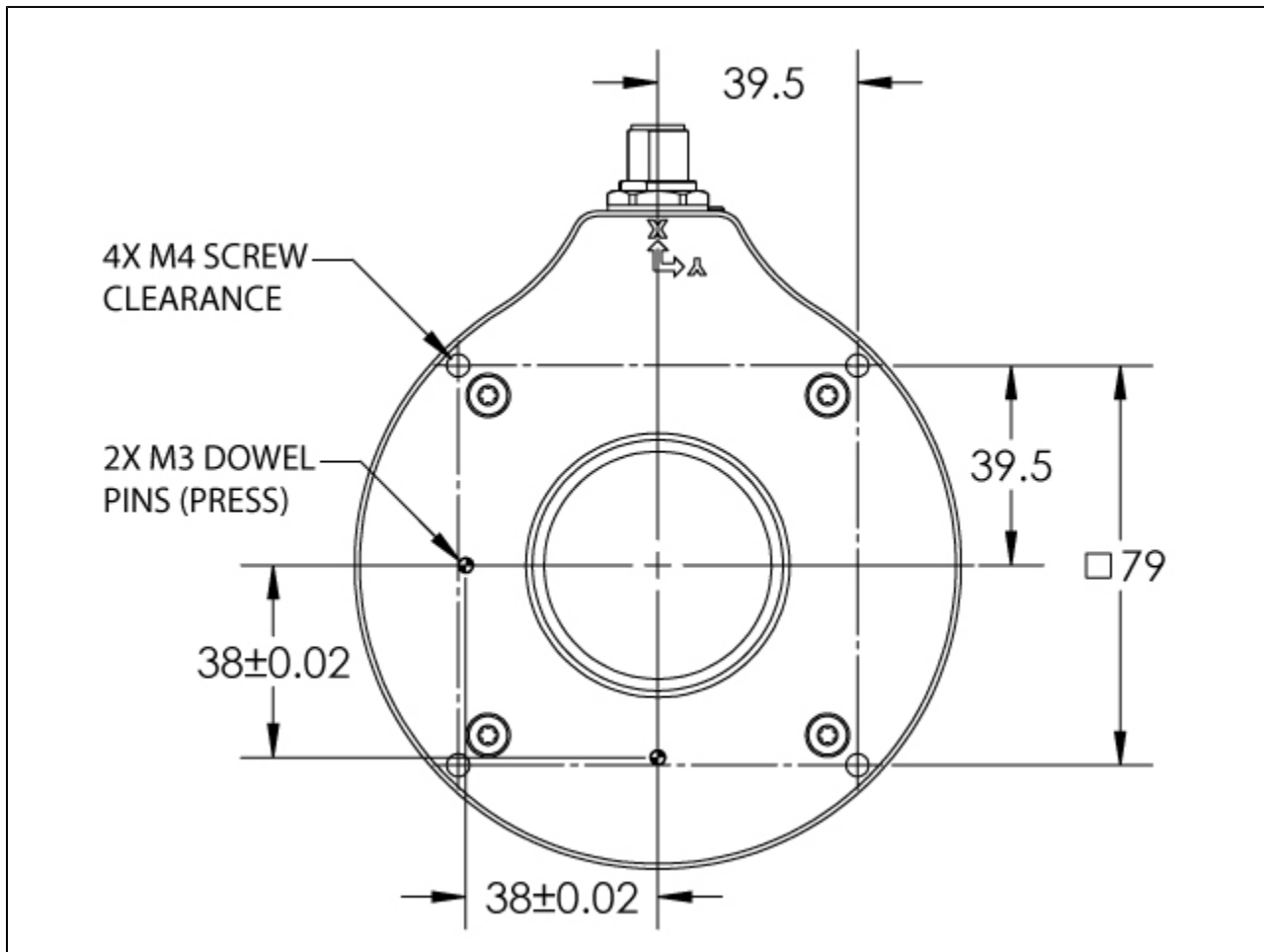

Figure 5.1.1.1 : Robot side bolt pattern for the FT 150 Sensor.

The FT 300 version has different robot side patterns available, see Section 7. [Spare Parts, Kits and Accessories](#) for more details.

5.1.2 Tool side bolt pattern

Figure 5.1.2.1 shows the bolt pattern used for tool fixation on the FT 150 Sensor.

- Mounting holes are M4 thread, 10 mm deep.
- Indexing hole for M6 dowel pin is slip fitted and 6 mm deep.
- Outside diameter of the flange is 64 mm and inside is 45 mm.

Note

Sensor tool flange must only make contact with the end effector tool flange within the 45 to 64 mm diameter range. Make sure that no other point of the FT 150 Sensor is in contact with the tool. Failure to do so will result in unpredictable force and torque readings from the Sensor.

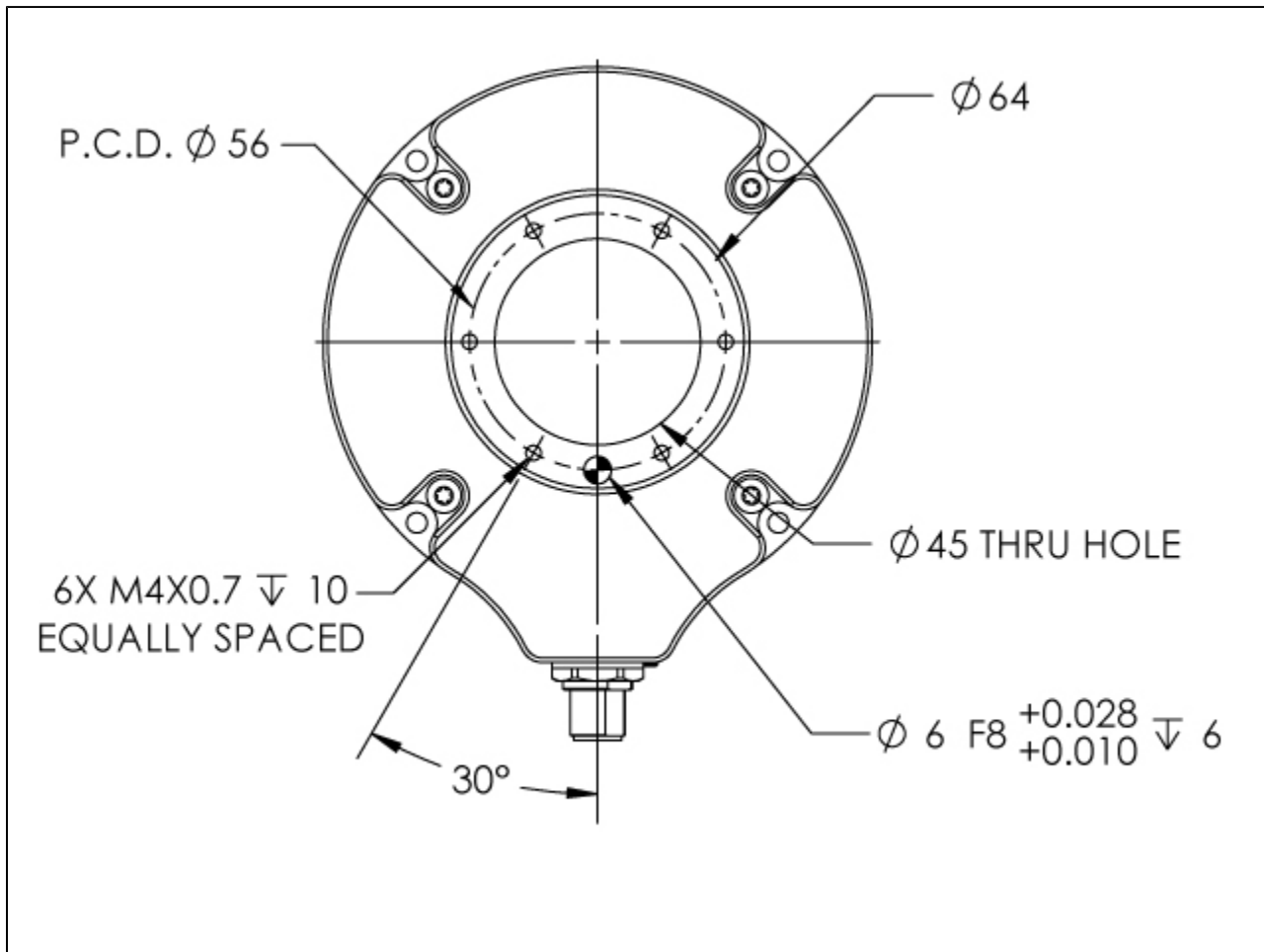

Figure 5.1.2.1 : FT 150 Sensor tool side bolt pattern.

Figure 5.1.2.2 shows the bolt pattern used for tool fixation on the FT 300 Sensor.

- Bolt pattern diameter is 50 mm
- Mounting holes are M6 thread, 6 mm deep.
- Indexing hole for M6 dowel pin has a tight fit (H7) and 6 mm deep.
- Outside diameter of the flange is 64 mm and inside is 45 mm.

Info

FT 300 tool side bolt pattern matches ISO-9409-1-50-4M6

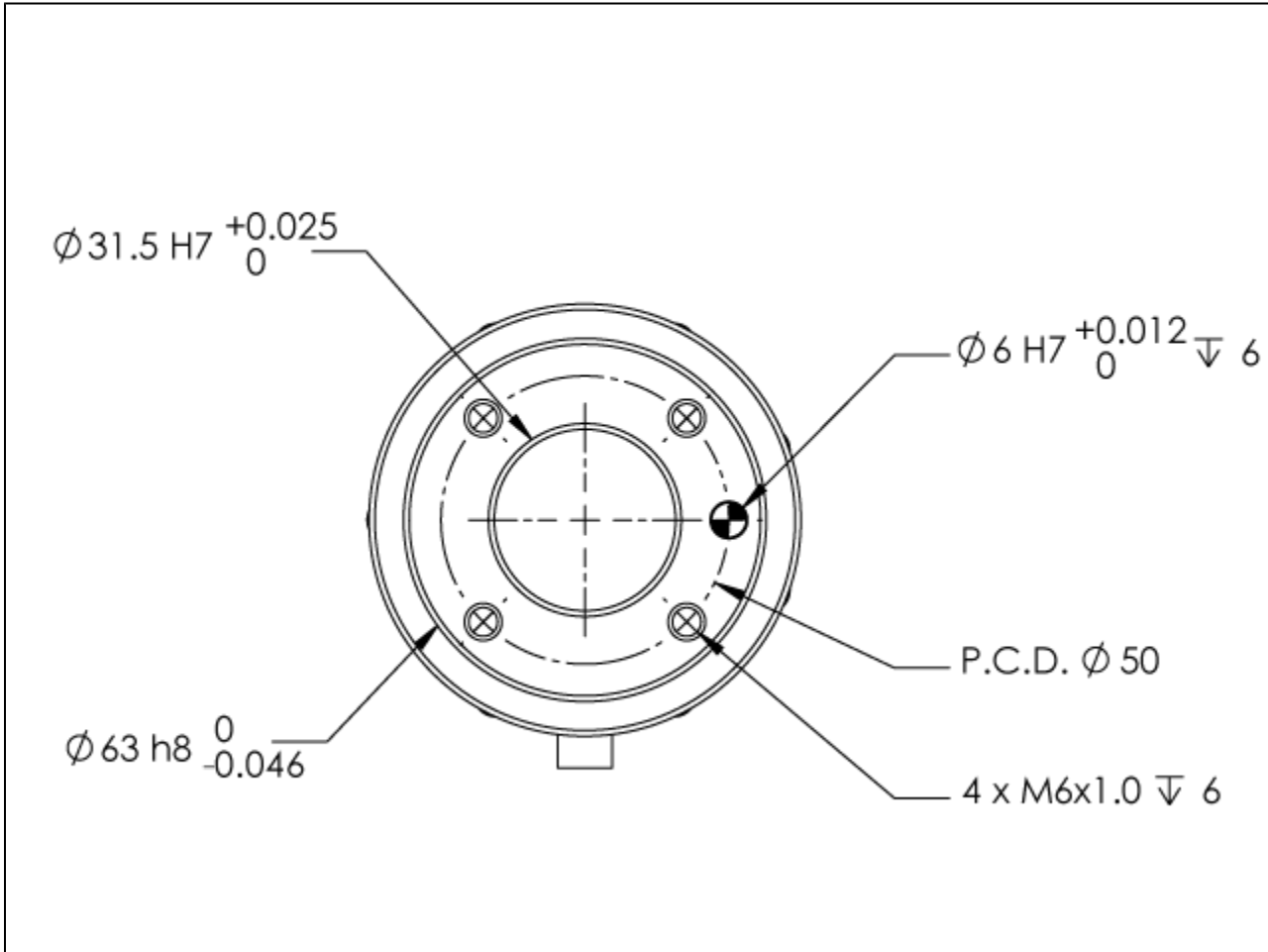

Figure 5.1.2.2 : FT 300 Sensor tool side bolt pattern.

5.2 Mechanical specifications

Info

Reminder, all units are metric units.

SPECIFICATION	FT 150	FT 300
Approximate Weight	650 g	300 g
Maximum load (all axes)	750 N (500%) ²	1500 N (500%) ²
Outside diameter	120 mm	75 mm
Through-hole diameter	45 mm	N/A
Thickness	37.5 mm	37.5 mm
IP rating	54 ¹	43 ¹

Stiffness	F_x, F_y	$3.2 \times 10^6 \text{ N/m}$	F_x, F_y	$35 \times 10^6 \text{ N/m}$
	F_z	$3.9 \times 10^6 \text{ N/m}$	F_z	$30 \times 10^6 \text{ N/m}$
	M_x, M_y	4700 Nm/rad	M_x, M_y	10000 Nm/rad
	M_z	4600 Nm/rad	M_z	20000 Nm/rad

¹ : Expected rating, certification is planned and will be forthcoming (see manual revision date).

² : Maximum load expressed in % of measuring range.

5.2.1 Moment of inertia and center of mass

The coordinate system used for calculating the moment of inertia and center of mass for the FT Sensor is shown in Figure 5.1.1.

Info

All values are approximate. Actual coordinates may vary according to various options present on the Sensor.

Here is the approximate position of the center of mass for the FT Sensor :

Sensor	Combination	x (mm)	y (mm)	z (mm)	Mass (grams)
FT 300	-	0	0	17	300
	2-Finger 85	0	0	76	1205
	2-Finger 140	0	0	83	1275
	Wrist Camera	0	2	30	530
	Wrist Camera and 2-Finger 85	0	1	77	1275
	Wrist Camera and 2-Finger 140	0	1	85	1340
FT 150	(with UR adapter plate)	1	-1	22	790

Here is the approximate moment of inertia matrix for the FT Sensor, taken at the coordinate system origin :

FT 150

$$I = \begin{bmatrix} I_{xx} & I_{xy} & I_{xz} \\ I_{yx} & I_{yy} & I_{yz} \\ I_{zx} & I_{zy} & I_{zz} \end{bmatrix} = \begin{bmatrix} 748 & 0 & 4.5 \\ 0 & 799 & 0 \\ 4.5 & 0 & 1391 \end{bmatrix} \text{ kg} \cdot \text{mm}^2$$

FT 300

$$I = \begin{bmatrix} I_{xx} & I_{xy} & I_{xz} \\ I_{yx} & I_{yy} & I_{yz} \\ I_{zx} & I_{zy} & I_{zz} \end{bmatrix} = \begin{bmatrix} 262 & 0 & 1 \\ 0 & 265 & 1 \\ -1 & 1 & 219 \end{bmatrix} \text{ kg} \cdot \text{mm}^2$$

Figure 5.2.1.1 : Moment of inertia of the FT Sensor 150 and 300.

5.2.2 Overload Capacity

PREVIOUS SECTION / NEXT SECTION

The FT 300 and FT 150 sensors have overload capacities, the overload capacity specification includes loads and torques in all 3 axes.

Info

For loads between the measuring range and the overload capacity, the signal will be saturated. The sensor will not undergo permanent damage if the overload capacity is not reached.

Important

Exceeding the overload capacity will permanently damage the sensor.

Sensor	Measuring range	Overload capacity ¹
FT 150	+/- 150 N	750 N (500%) ²
FT 300	+/- 300 N	1500 N (500%) ²

¹ : Overload capacity with all axes combined.

² : Maximum load expressed in % of measuring range.

The overload capacity given includes forces and torques in all 3 axes. To get an approximation of the total load, these formulas must be used :

- For the FT 300 :

$$F_x/300 + F_y/300 + F_z/300 + M_x/30 + M_y/30 + M_z/30 < 500\%$$

- For the FT 150 :

$$F_x/150 + F_y/150 + F_z/150 + M_x/15 + M_y/15 + M_z/15 < 500\%$$

PREVIOUS SECTION / NEXT SECTION

5.3 Signal specifications

SPECIFICATION		FT 150	FT 300
Measuring range	Force	± 150 N	±300 N
	Torque	± 15 Nm	± 30 Nm
Signal noise	Fx, Fy	0.5 N	1.2 N
	Fz	0.25 N	0.5 N
	Mx, My	0.015 Nm	0.02 Nm
	Mz	0.02 Nm	0.03 Nm
Recommended threshold	Fx, Fy	2 N	5 N
	Fz	1 N	2 N
	Mx, My	0.06 Nm	0.08 Nm
	Mz	0.08 Nm	0.12 Nm
External noise sensitivity	Immune ¹		
Cross-talking	None ²		
Drift	Force	± 3 N over 24h	?
	Torque	non-significant	non-significant
Data output rate	100 Hz		

Temperature compensation	15 to 35 °C
--------------------------	-------------

¹ For example, welding current passing through the Sensor hole will not affect the readings.

² The sensing elements are aligned with the measurement axis, such that they are not affected by efforts in other axes.

Recommended threshold

The recommended threshold represents the smallest variations that can be detected by the sensor.

The signal noise is greater than the Sensor's resolution, thus it is the limiting factor for the Sensor's precision. For the FT 300, the signal noise defined in the signal specifications is the standard deviation of each data (Fx, Fy, Fz, Mx, My, Mz) over 1 second. In order to use that signal noise information, three times the standard deviation given must be used. According to the normal distribution, three times the standard deviation will cover almost all values possible (99.7%). For the FT 150, the signal noise defined in the signal specifications is the standard deviation of all data (Fx, Fy, Fz, Mx, My, Mz) over 10 seconds.

What is signal noise?

Noise is an unwanted and unpredictable alteration to a signal. It may come from electrical or electromagnetic sources and degrades the quality of the Sensor's signal.

5.4 Electrical ratings

SPECIFICATION	FT 150 VALUE	FT 300 VALUE
Input voltage	6 to 28 V DC \pm 10%	5 to 24 V DC \pm 10%
Max power consumption	2 W	
Communication electrical interface	RS-485	
Recommended fuse	Phoenix #0916604 (UT6-TMC M 1A)	
Recommended power supply	TDK-Lambda DPP Series, <i>15W Single Output DIN Rail Mount Power Supply</i> , DPP15-24	

5.5 Couplings

For a detailed list of available Couplings and Adapter Plates please consult [Section 7. Spare Parts, Kits and Accessories](#).

The following sub-sections contain data required for custom couplings or creating couplings from blanks.

Info

All Robotiq couplings and adapter plates are provided with necessary hardware for fixation on the Robotiq device side.

Note

Unless identified for specific packages only, **robot side screws and indexing pins are not provided.**

5.5.1 Blank coupling

Schematics of Figure 5.5.1.1 below represent optional Blank Coupling for the FT 150 Sensor :

- (4) M4 thread and indexing pin holes are meant to affix the FT 150.
- The circular central section of 71 mm diameter (blue section of Figure 5.5.1.1) is available for custom bolt patterns for robot side fixing.
- Spare part list number is FTS-CPL-BLANK.

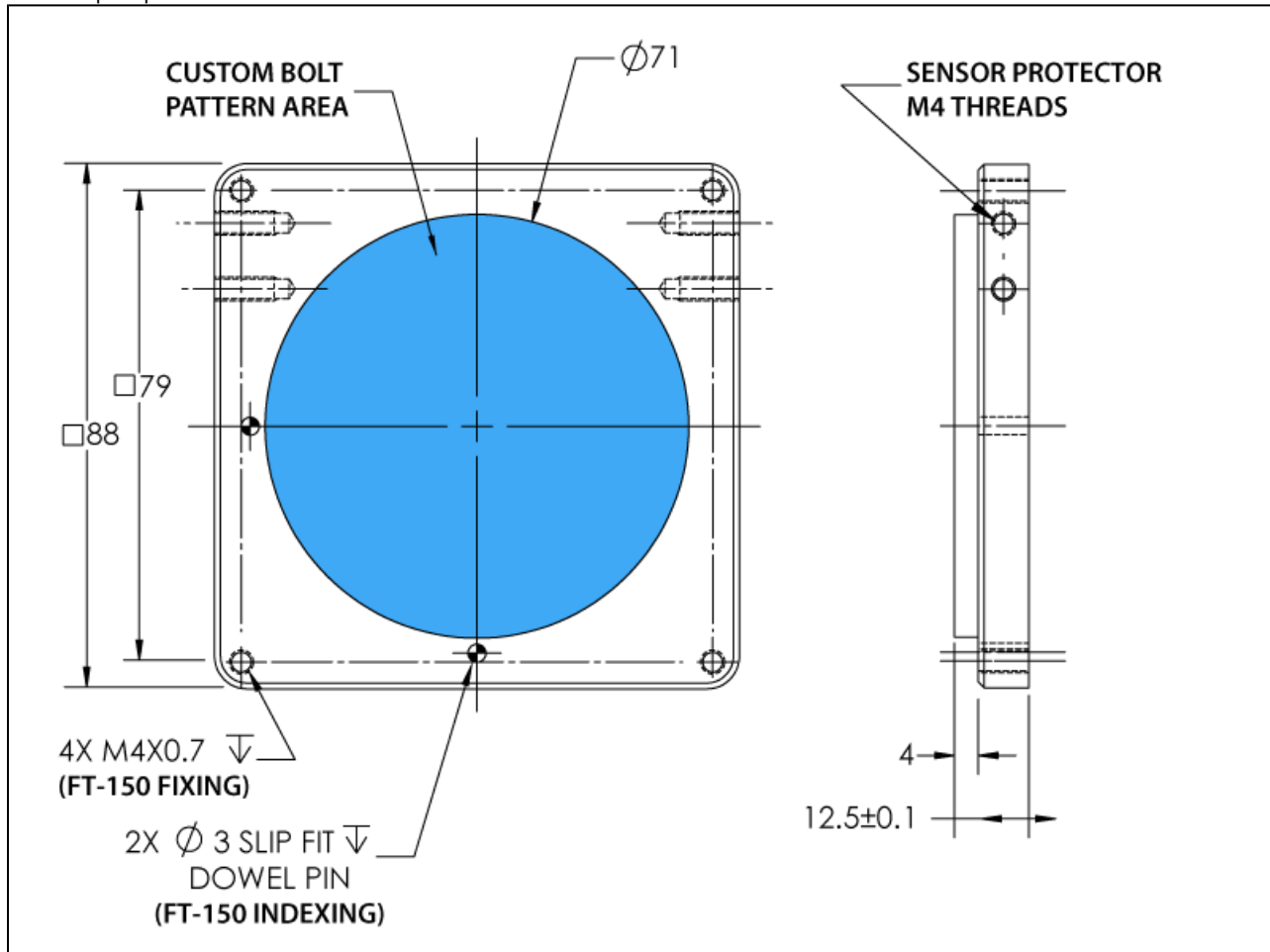

Figure 5.5.1.1 : Technical dimensions of the blank coupling for the FT 150.

Figure 5.5.1.2 schematics represent the optional blank coupling for the FT 300 Sensor :

- (7) M4 threads and the 63 mm (H8) circle are meant to affix the FT 300.
- The circular section of 75 mm diameter (blue section of Figure 5.5.1.2) represents the customization area and has a depth of 5 mm.

Warning
 Make sure your custom design does not interfere with the M4 threads or the 63 mm, H8 centering circle.

- Spare part list number is FTS-300-CPL-BLANK

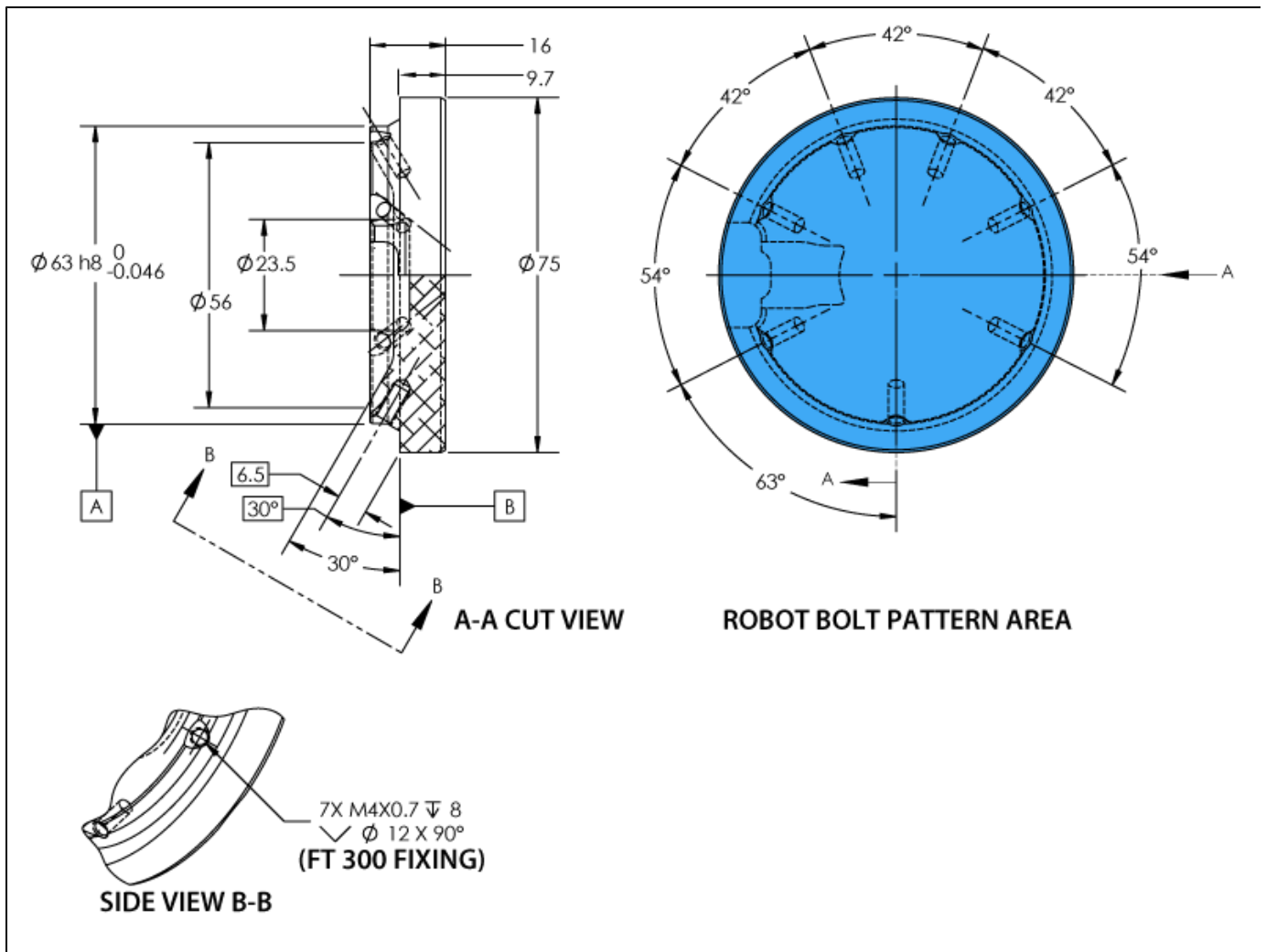

Figure 5.5.1.2 : Technical dimensions of the blank coupling for the FT 300.

6. Maintenance

The Robotiq Force Torque Sensor requires only external maintenance with limited downtime.

Maintenance of the Sensor is required after specified usage, measured in time (normal 40h week). Following the maintenance interval will ensure :

- Correct functioning of your Sensor.
- Validity of your warranty.
- Proper lifetime for your Sensor.

Please visit support.robotiq.com for details on the maintenance operation.

Warning

Unless specified, any repairs done on the FT Sensor will be done by Robotiq.

Maintenance Intervals :

Operation	Daily	Weekly	Semiannually
Zero calibration	x ¹		
Sensor cleaning	Dirty conditions	Normal conditions	
Periodic inspection			x ²

¹ Zero calibration should be integrated into the program routine. This will compensate for the tool weight (for its current orientation), the effect of the attachment mechanisms on the Sensor and any other factors which could affect the readings. It is recommended to add this instruction when the robot is not applying force on its environment and when the tool is in the same orientation as when the readings will be used (for example at the beginning of the program or just before picking up an object or applying force).

² If there is any visible damage to the Sensor, contact Robotiq support.

7. Spare Parts, Kits and Accessories

The following list is up to date at print time and is subject to change, check [online](#) for updates.

Info

Unless specified, screws, dowel pins and other hardware are included only for the Sensor side, never for the robot side.

Item	Description	Ordering Number	
		FT 150	FT 300
Standard Kit	Robotiq Force Torque Sensor FT , includes cable and USB converter.	FTS-150-KIT-001	FTS-300-KIT-001
Kit for <i>Universal Robots</i>	Standard Sensor with Couplings for <i>Universal Robots</i> and software package.	FTS-150-UR-KIT	FTS-300-UR-KIT
Sensor	Replacement sensor, sensor alone.	FTS-150-SEN-001	FTS-300-SEN-001
Blank coupling	Blank coupling with FT bolt pattern on one side and the other side clear.	FTS-150-CPL-BLANK	FTS-300-CPL-BLANK
Coupling 56-6M4-1D6	Coupling for 56 mm PCD ¹ (6) M4 thread and (1) 6 mm M6 indexing pin.	FTS-150-CPL-101	N/A
Coupling 56-8M4-1D4	Coupling for 56 mm PCD ¹ (8) M4 thread and (1) 4 mm M6 indexing pin.	FTS-150-CPL-102	N/A
Coupling 50-4M6-1D6	Coupling for 50 mm PCD ¹ (4) M6 thread and (1) 6 mm M6 indexing pin. To be used on UR robots.	FTS-150-CPL-103	FTS-300-CPL-062
Coupling 39-8M3-1D3	Coupling for 39 mm PCD ¹ (8) M3 thread and (1) 3 mm indexing pin.	N/A	FTS-300-CPL-069
Coupling 40-4M6-1D6	Coupling for 40 mm PCD ¹ (4) M6 thread and (1) 6 mm M6 indexing pin.	FTS-150-CPL-111	FTS-300-CPL-064
Coupling 31_5-4M5-1D5	Coupling for 31.5 mm PCD ¹ (4) M5 thread and (1) 5 mm M6 indexing pin.	FTS-150-CPL-106	FTS-300-CPL-063
Coupling 31_5-4M5-1D5-M	Coupling for 31,5 mm PCD ¹ (4) M5 thread and (1) 5 mm indexing pin.	FTS-150-CPL-112	N/A
Coupling 80-6M8-2M8	Coupling for 80 mm PCD ¹ (6) M8 thread and (2) 8 mm M6 indexing pin.	FTS-150-CPL-107	N/A
Coupling 50-6M6-1D6	Coupling for 50 mm PCD ¹ (6) M6 thread and (1) 6 mm M6 indexing pin.	FTS-150-CPL-108	N/A
Coupling 63-4M6-61_4-1D6	Coupling for 63 mm PCD ¹ (4) M6 thread and (1) 6 mm M6 indexing pin on 61.4 mm PCD.	FTS-150-CPL-110	N/A
Tool plate F-104	Tool side plate for conversion between FT and 50 PCD ¹ 4M6-1D6 bolt pattern	FTS-150-TOOL-104	N/A
Tool plate F-105	Tool side plate for conversion between FT and 56 PCD ¹ 8M4-1D4 bolt pattern	FTS-150-TOOL-105	N/A
Tool plate F-109	Tool side plate for conversion between FT and 40 PCD ¹ 4M3-1D3 bolt pattern	FTS-150-TOOL-109	N/A
Robotiq Device Cable	5 or 10 m cable for power and communication with the FT Sensor	CBL-COM-2054-05 or -10	CBL-COM-2067-05 or -10
FT Connector Protector	Cable connector protector (only for Sensor FT 150)	FTS-150-PRO-001	N/A

¹ Pitch Circle Diameter

8. Troubleshooting

The following are some common troubleshooting hints, if you need further assistance please contact the Robotiq Support team.

General Troubleshooting

An Offset has Appeared in the Sensor Data

- Changes in ambient conditions can cause an offset in the sensor signals.
- An offset can also be caused if the sealing o-rings are displaced during an overload.
- These offsets do not account for a decalibration of the Sensor as they are in fact recognized as effort applied to the Sensor. Any additional force applied on the tool side of the Sensor will be read normally.
- In all cases, it is recommended to have a software offset which compensates for these variations in addition to the effort caused by the tool weight for a given orientation. It is preferable to set the software offset before starting to use the sensor data such that the robot software uses a proper and consistent reference.

Procedure to Determine if the Sensor is Functional

- Verify that the Sensor is connected according to the [Installation section](#) of this manual.
- When powered, verify that the LED on the Sensor is blue (not red/blue).
 - FT 150 LED is blue if functional (streaming)
 - FT 300 LED is red if powered without communication, blue if powered with communication
- Power-off the Sensor and then connect the provided USB/485 converter to a USB port of a Windows PC.
 - In the Windows PC, open the Device Manager.
 - You should see a "USB Serial Port" device in the "Ports (COM & LPT)" category. If not, it is possible that the converter drivers have not installed automatically. You can download the driver from the ftdichip.com website.
- Power the Sensor with the recommended voltage.
- Download the simple data logger application at: support.robotiq.com
- Run the data logger application. Enter 100 for the number of data per 10 seconds and any file name (for example "test.csv").
- Verify that the sensor data is displayed in the Windows console application.

Troubleshooting on Universal Robots

ActiveDrive Toolbar Troubleshooting - Error Messages Overview

The ActiveDrive toolbar will be automatically collapsed and be grayed whenever one of the following situations occurs. In such cases, by tapping the ActiveDrive button, the following messages will appear:

- Message:

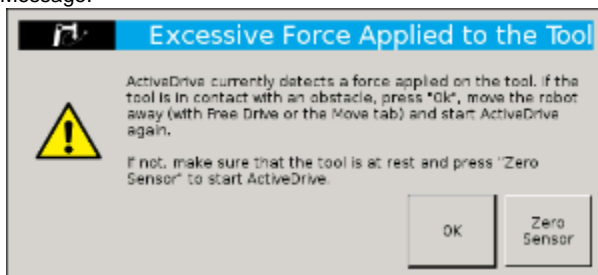

- Solution:
 - Starting ActiveDrive while an excessive force is applied to the tool:
 - Determine if an external force is applied to the end-effector. If it is the case, tap "OK" and move the robot away from the obstacle (with Free Drive or Move tab), or remove any external forces and start ActiveDrive again.
 - If no external forces are applied, tap "Zero Sensor".
- Message:

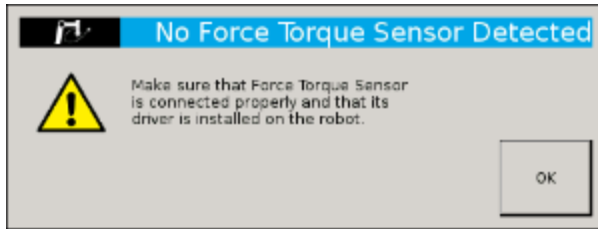

- Solution:
 - Force Torque Sensor is detected: Check the Force Torque Sensor's connection. Make sure the USB adapter and all the wires are well connected. Also verify the Sensor's LED status (see Section 3.7).

• Message:

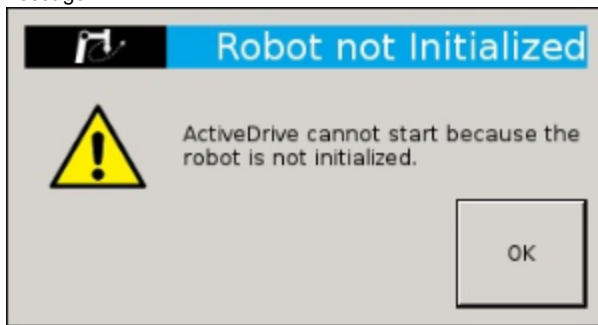

- Solution:
 - The robot is not initialized: Tap "OK" and go to Polyscope's home page. Tap Setup Robot and go in Initialize Robot to start the robot.

• Message:

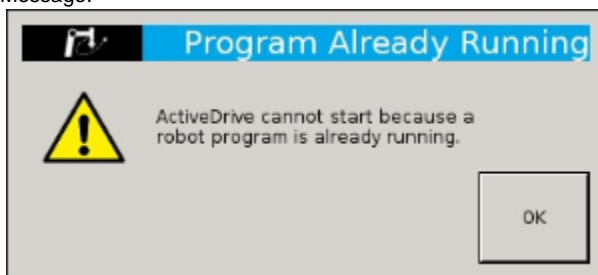

- Solution:
 - A program is already running: The ActiveDrive toolbar cannot be used while a program is running. Stop the program to enable the ActiveDrive feature.

• Message:

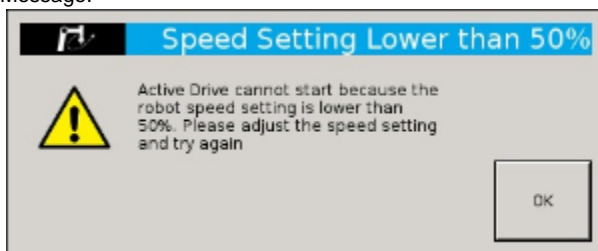

- Solution:
 - The speed setting of the robot is lower than 50%: The robot's speed setting should be greater than 50%. Modify the speed setting in the robot's program with the slider.

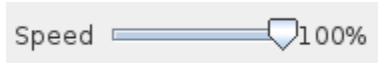

• Message:

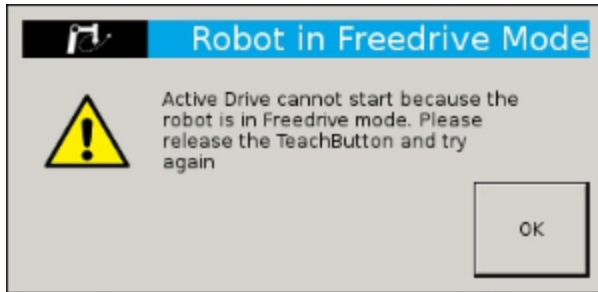

- Solution:
 - If the Freedrive button is pressed: The ActiveDrive mode cannot be used when the Free Drive mode is on. Make sure you are not pressing on the teach pendant's Teach button when trying to use the ActiveDrive toolbar.

Troubleshooting on other platform

USB Converter Detected as a Mouse by Windows

- In Windows, the USB converter is sometimes detected as a mouse, making the cursor move. This is a well known problem in Windows: <http://support.microsoft.com/kb/819036>
- A simple workaround is to plug in the USB converter before powering the Sensor. Once the USB driver is initialized in Windows, the Sensor can be powered and used without a problem.

Data Frequency under 100 Hz in Windows

- By default, the USB to RS-485 converter has a latency setting of 16 ms in Windows (1 ms in Linux), which will prevent the application software from receiving new messages at 100 Hz (it will often read two sensor messages in the buffer at the same time).
- In the Windows Device Manager, right click on the virtual COM port for the Sensor and select "Properties". In the "Port settings" tab, click on "Advanced". Adjust the latency timer to "9 ms" (it is not recommended to lower it too much in Windows since other connectivity issues may arise), then click "ok".

In Linux, the Serial Port cannot be Opened

- By default, a user does not have access to the serial ports.
- It is possible to provide this access by adding the user to the dialout group with the following command:

```
rd@debian:~/~$ sudo usermod -a -G dialout username
```

9. Warranty

Robotiq warrants the Force Torque Sensor FT 150 / FT 300 against defects in material and workmanship for a period of one year from the date of reception when utilized as intended with the specified maintenance. Robotiq also warrants that this equipment will meet applicable specifications under normal use.

Warranty applies under the following conditions:

- Usage respects the operating, transporting and storage conditions specified in [Section 3.2](#)
- Usage under normal one-shift operation (40h a week)
- Usage respects maintenance specified in [Section 6](#)

During the warranty period, Robotiq will repair or replace any defective product, as well as verify and adjust the product free of charge if the equipment should need to be repaired or if the original adjustment is erroneous. If the equipment is sent back for verification during the warranty period and found to meet all published specifications, Robotiq will charge standard verification fees.

The unit is considered defective when at least one of the following conditions occurs:

- The Sensor feedback is not accessible.
- Sensor signal noise is over twice the specified limit.

Caution

The warranty will become null and void if the:

- Unit has been tampered with, repaired or worked on by unauthorized individuals.
- Warranty sticker has been removed.
- Screws, other than as explained in this guide, have been removed.
- Unit has been opened.
- Unit serial number has been altered, erased, or removed.
- Unit has been misused, neglected, or damaged by accident.

This warranty is in lieu of all other warranties expressed, implied, or statutory, including, but not limited to, the implied warranties of merchantability and fitness for a particular purpose. In no event shall Robotiq be liable for special, incidental, or consequential damages.

Robotiq shall not be liable for damages resulting from the use of the product, nor shall be responsible for any failure in the performance of other items to which the product is connected or the operation of any system of which the product may be a part.

Exclusion

Robotiq reserves the right to make changes in the design or construction of any of its products at any time without incurring an obligation to make any changes whatsoever on units already purchased.

This warranty excludes failure resulting from: improper use or installation, normal wear and tear, accident, abuse, neglect, fire, water, lightning or other acts of nature, causes external to the product or other factors beyond Robotiq's control.

10. Contact

www.robotiq.com

[Go to Contact Us](#)

Phone

1-888-ROBOTIQ (762-6847)

(01) 418-380-2788 Outside US and Canada

Fax

1-418-800-0046

Technical support and Engineering

extension 207

Sales

extension 124

Head office

Robotiq:

966, chemin Olivier

Suite 325

St-Nicolas, Qc

G7A 2N1

Canada

A. Harmonized standards, declarations and certificates

A1. Translation of original EC declaration of incorporation



Translation of original declaration of incorporation

In terms of the Directive 2006/42/EC, Annex II, part B of the European Parliament and of the Council on machinery,

We, the manufacturer, **Robotiq Inc.**
966, Chemin Olivier, suite 325
Lévis, Québec, Canada, G7A 2N1

Hereby declare that the following product:

Robotiq Force Torque Sensor FT 150 & FT 300
Identified F-1001 / G-1001 and over

Meets the applicable basic requirements of the Machinery Directive 2006/42/EC

The incomplete machine may not be put into operation until conformity of the machine into which the incomplete machine is to be installed with the provisions of the Machinery Directive is confirmed. Compliance with all essential requirements of Machinery Directive relies on the specific robot application and overall risk assessment.

The manufacturer agrees to forward on demand of national authorities the relevant technical documents specified by Annex VII part B within the required time.

Additionally the product declares in conformity with the following directives, according to which the product is CE marked:

- 2014/30/EU Electromagnetic Compatibility Directive (EMC)
- 2011/65/EU Restriction of the use of certain hazardous substances (ROHS)

Person responsible for documentation: Mr. Étienne Samson, address: see manufacturer address

Lévis, July 2016
(place and date of emission)

A handwritten signature in dark ink, appearing to read "J. Jobin", written over a faint horizontal line.

Jean-Philippe Jobin
Chief Technical Officer
Robotiq Inc.

A2. Applied standards

This section describes all applied harmonized standards for the design and production of the Robotiq Force Torque Sensor (both FT 150 and FT 300). Standards are applied where applicable, some points may not be applied if not applicable to this specific product. Conformity is not enforced by any laws, it is self-applied and the aim is to define normal safety and performance requirements for similar products.

Note

Conformity of the product is only met if all instructions of the following manual are followed. Among others; installation, safety measure and normal usage must be respected.

The following standards have been applied :

NF EN ISO 12100	2010	Safety of machinery — General principles for design — Risk assessment and risk reduction
NF EN IEC 60204-1	2006	Safety of machinery — Electrical equipment of machines — Part 1: General requirements