

VISION SYSTEMS

Product Guide

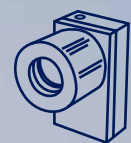
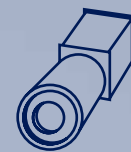

VISION SYSTEMS

The Vision Systems product line of Datalogic is built upon the acquisition of PPT Vision Inc. in 2011. For over 30 years, PPT Vision has focused exclusively on the development of vision systems technology for in-line automated inspection and factory automation. By expanding PPT Vision's extensive experience of thousands of successful vision systems installations throughout the world, Datalogic has become a recognized world leader in vision systems innovation and has brought unique benefits to customers:

A single software platform for all our vision systems

Our intuitive **IMPACT** programming software is common to all smart cameras and industrial vision processors. This means no operator cross-training and no need to maintain different software platforms— just select the hardware you want and go! Transfer inspection programs from a smart camera to an industrial vision processor and back again without redeveloping the application.

Performance where you need it

A suite of hardware and software that enables our customers the flexibility to solve their machine vision application. The **IMPACT** software is a proven platform that allows users to solve machine vision inspections with an intuitive drag and drop environment and complete library of algorithms. **IMPACT** also allows a user to set up a user interface that is secure, configurable, and able to set up quickly. Connect and view data from one or many vision systems with just a click of a button.

Hardware platforms that allow our customers to expand their range of applications. From standalone compact smart cameras to the highest performance industrial vision processors, we can deliver a vision system optimized for your inspection needs. Choose a smart camera with color or grayscale sensor or an industrial vision processor with a high resolution camera; it does not matter because we have you covered

Solutions for Industry 4.0

A crucial role in the creation of "smart factory" for Industry 4.0 will be played by companies that are able to generate data. Our customers are able to expand Traceability beyond the barcode by also reading characters (OCR) and identifying the object by its pattern. By detecting defects and locating parts our systems are able to guide robots and other automation to help control the process of the manufacturing line. Data is key and machine vision is able to provide what is needed in today's environment.

Time-to-market

Personalized, technically superior and committed customer support. We can provide you with as much support as you need when it comes to delivering application solutions. Choose one of our highly skilled and qualified application engineers or training specialists, or select a certified partner to guide you from application concept to installation and qualification of your system.



KEY BENEFITS

VISION SYSTEMS PRODUCT GROUP

- Smart Cameras
- Industrial Vision Processors
- Vision Systems Software

Our complete family of high-performance smart cameras and industrial vision processors utilizes the same software across all products.

These products are specifically designed and developed by our engineers to meet all your manufacturing inspection requirements and to get your application up and running faster than anyone else in the industry – Guaranteed!

INNOVATION

Through continuous development and refinement, our product line is the most complete hardware and software solution available on the market today.

EXPERIENCE

With over 30 years in the vision systems business and thousands of successful customer installations, our organization and partners are able to solve the most challenging inspection applications within a wide variety of markets and manufacturing settings.

RESPONSIVENESS

Together with our global distribution and integration partners pride our self on providing a level of training and support that is unmatched in the industry. We listen, then execute – turning our customers' requirements into solutions faster than anyone else.



P-SERIES SMART CAMERA

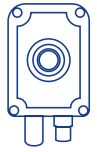

P-SERIES

The P-Series is an ultra-compact cost effective smart camera offering advanced vision systems functionalities in a fully embedded stand-alone device. The P-Series is available with grayscale or color image sensors with two different resolutions: 640x480 pixels at over 120fps and 1280x1024 pixels at up to 60fps. Lenses and illuminators are fully interchangeable and can be mounted and replaced by the user. Powered by IMPACT, the P-Series is the perfect product to tackle vision systems applications in food & beverage, pharmaceutical and automotive industries where the ease of use, compactness and the price/performance ratio are the most important buying criteria.



HIGHLIGHTS

- Fully embedded ultra-compact device
- Rotating connectors for 0° & 90° form factors
- Rugged IP67 rated housing
- VGA and 1.3 megapixel resolutions
- Grayscale and color sensors
- Interchangeable lenses, illuminators and filters
- Built-in Serial and Ethernet interfaces

Applications

- Bottle cap inspection
- Label position, orientation and color
- Packaging/sealing verification
- Vial in tray counting
- Inspection of flip-off caps (presence and color)
- Component assembling verification
- Component alignment/positioning
- Lot and batch number reading
- Expiration date verification
- Serial number traceability
- Robot Guidance

Impact + OCR

IMPACT+ OCR is a turn-key solution designed for Optical Character Recognition applications in Food & Beverage industry. It includes the compact bestselling P-Series Smart Camera (P19) powered by dedicated and easy-to-use OCR software. Combined with thermal transfer printers, IMPACT+ OCR guarantees the highest printing quality which in turn enhances traceability of Food & Beverage packaging processes. Expiration dates, serial and lot numbers can be easily read and verified.

Food packaging

Traceability is critical in understanding the source of our food and also what is contained within the package. When there is a food safety issue, effective traceability will help with the product recall. Traceability can include machine readable information contained within barcodes; human readable information such as date and lot codes or batch information; and product identification by the package graphics. All of this information can help ensure the quality of our food.

A/T -SERIES SMART CAMERA



A/T-SERIES

The Datalogic smart camera products are standalone, general-purpose, industrialized vision systems inspection systems with especially flexible programming through the IMPACT software. Two product series cover different price/ performance needs: the general purpose A-Series and the extremely powerful T-Series. With models ranging from 640x480 pixel resolution up to 5 Megapixels, IP67 industrial rating, built in discrete I/Os, onboard serial and Ethernet interfaces, the A and T-Series smart cameras can deliver the right solution for your vision systems needs.



HIGHLIGHTS

- Two product series for different performance and price point requirements
- Multiple imager resolutions to meet your accuracy needs
- Fully capable smart camera for the most demanding applications
- Processing power to keep up with your production line and provide data for IoT
- Industrially hardened enclosure - IP67 rating
- Full Serial and Ethernet communication capability
- Built in discrete I/Os
- 90 degree format

Applications

- Robot Guidance
- Packaging artwork verification
- Medical device assembly control
- Dashboard inspection
- Electric fuse box inspection
- Precision Repeating Measurements (Measuring Integrated Circuit Contacts)
- Surface flow detection
- Plastic Molding Short Shot Detection (Carrier Tape Inspection)
- Pattern Finding (Locating and Identifying Product Orientation)

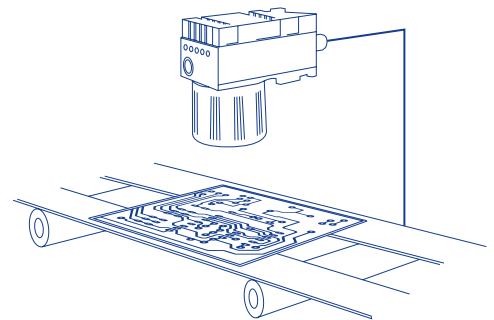

Electronic

The T4x-Series product is a high performance, ruggedized smart camera that can address most single camera inspection needs. The T4x-Series product incorporates high quality imagers, a class rating of IP67 and the latest in high performance processors. This makes it perfectly suited for the demands of high density pin inspections in the automotive and telecom industries. These connectors require not only verification of pin presence, but also high precision measurements across, potentially, several hundred pins and key feature locations.

VISION PROCESSORS



MX-E/MX-U SERIES

Industrial vision processors provide the highest performance in image processing with even more flexibility through multi-camera support. Connect to multiple camera formats at one time (e.g. area scan, line scan, high resolution, etc. on same processor) via GigE (MX-E Series) or USB3.0 (MX-U Series) Vision standards. Three models allow you to choose the correct level of performance based on your application needs – from economical to high performance.

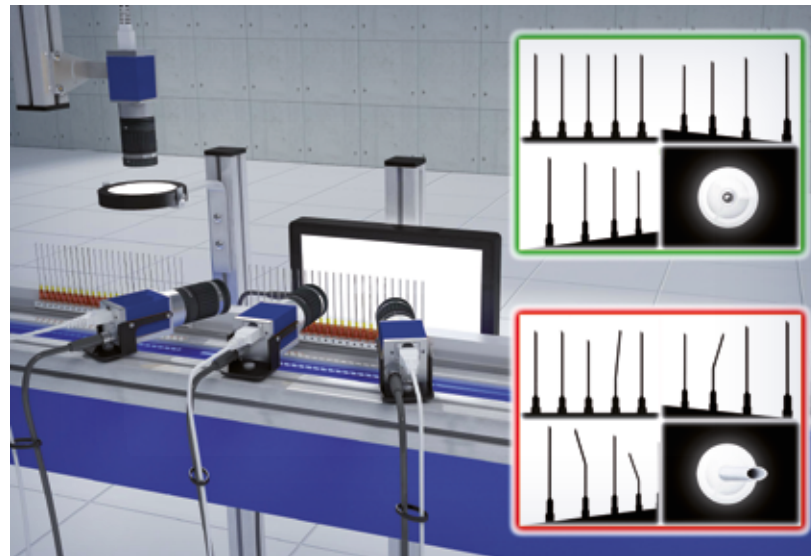

HIGHLIGHTS

- Three levels of high-powered image processing capability
- Seamless integration with standard factory networks and secondary software packages
- Many different cameras supported, including grayscale, color, high resolution, and line scan
- Use different cameras formats and resolutions on one processor
- Complete software tool set for ultimate programming flexibility
- No need for a secondary PC to view or retain images and inspection data

Applications

- High-Resolution Image Analysis (LCD Panel Inspection)
- High-Speed Product Inspection (Web or Continuous Part Inspection)
- Multi-Camera Inspection (Hypodermic Needle Inspection)
- Line scan Applications (Automotive or Telecom Connector Inspection)
- Image Unwrapping (Code Reading on Circular Objects)
- Robot Guidance

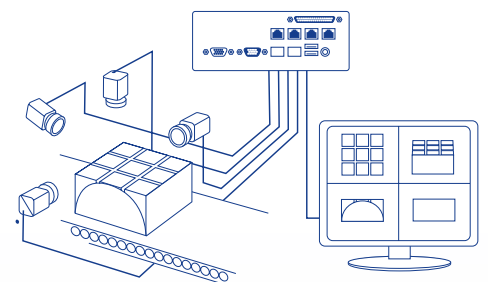

Medical

The MX-E Series vision processor product line up provides you with the most image processing performance in a fully integrated vision system. With multi-core processors, these systems can handle the most demanding high-speed and multicamera applications, such as hypodermic needle inspection. The needle application shown here requires the system to image and verify needle length, straightness, and epoxy presence from three different cameras, while a fourth camera checks for grinding defects at the end of the needle. This inspection is being performed at seventeen needles per second.

VISION SYSTEMS SOFTWARE



IMPACT SOFTWARE

IMPACT Software Suite, with over 120 software tools and controls, allows you to create unique inspection programs and develop user interfaces quickly and easily. All this can be done without the loss of functionality, like traditional configurable systems, no programming is required. IMPACT Software Suite also provides a Software Development Kit (SDK) that guarantees full integration of vision systems monitoring capabilities into HMI software applications. IMPACT SDK is the ideal solution for Original Equipment Manufacturers (OEM) that need to create a single control point for the whole manufacturing line. One software – countless applications!

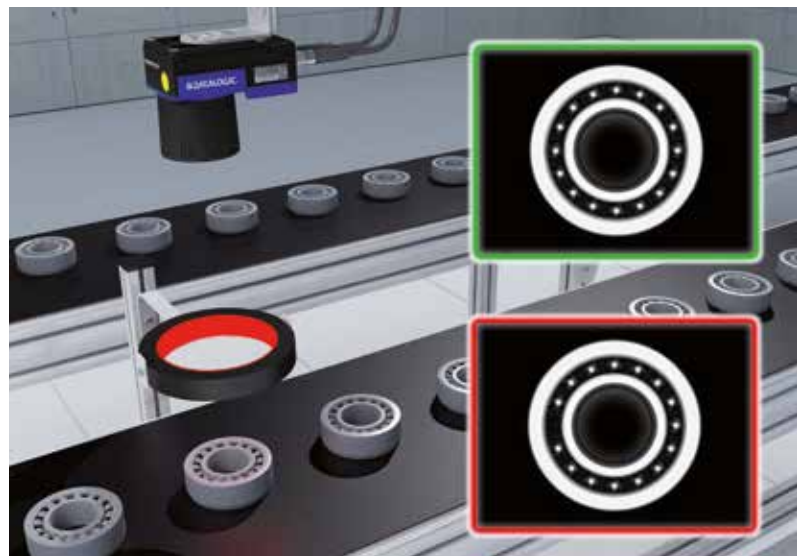

HIGHLIGHTS

- Graphical icon-based drag and drop user interface – no programming required
- Easy to understand, tree-view logic flow
- Tool Setups guide users through step-by-step tool configuration
- Includes inspection and user interface development programs as well as a runtime user interface
- Runs on all smart camera and vision processor platforms
- Provides a software development kit to integrate vision systems monitoring capabilities into HMI applications
- Provides real time parameter changes of cameras
- Controls and displays images and data from multiple smart cameras or vision processors
- Password protection allows only authorized users to make changes

Vision program manager (vpm) tools:

- Image Filtering
- Guidance and locating
- Flaw detection and Defect Finding
- Gauging
- Data and Communication
- Code Reading
- OCR - Optical Character Recognition
- Color

Software development kit (sdk) functionalities:

- Connecting/disconnecting to/from a vision device
- Displaying current images
- Cropped and subsampled image acquisition
- Inspection loading/unloading
- Getting all data types at the same time from current inspections
- Setting inputs to IMPACT tools, including ROIs (Regions Of Interest)
- Image and vision program uploading/ downloading
- Camera calibration settings

Guidance and traceability

Today's manufacturing lines need to maintain flexibility and efficiency. Manufacturers are creating smaller custom batches of products that are individualized. For example, each car that is manufactured may require different options that a customer selected, from the correct wheels to the type of radio. This type of customization requires that each component can be traced and available on the assembly line at the right time. Then using automation such as a robot to accurately pick the right component accurately and place it on the rest of the assembly.



Rev. 13, 03/2019



9C511200E

Product and Company names and logos referenced may be either trademarks or registered trademarks of their respective companies. We reserve the right to make modifications and improvements.

www.datalogic.com